

Rittal – The System.

Faster – better – worldwide.

Make **IT** easy.

ENCLOSURES

POWER DISTRIBUTION

CLIMATE CONTROL

IT INFRASTRUCTURE

SOFTWARE & SERVICES



FRIEDHELM LOH GROUP

Rittal – The System.

Faster – better – worldwide.



ENCLOSURES

POWER DISTRIBUTION

CLIMATE CONTROL

FRIEDHELM LOH GROUP

Rittal – The System.

The whole is more than the sum of its parts.

The same is true of “Rittal – The System.” With this in mind, we have bundled our innovative enclosure, power distribution, climate control and IT infrastructure products together into a single system platform. Complemented by our extensive range of software tools and global service, we create unique added value for all industrial applications: Production plant, test equipment, facility management and data centres. Following our simple principle, “faster – better – worldwide”, we combine innovative products with efficient service for optimum results.

Faster – with our “Rittal – The System.” range of modular solutions, which guarantees fast planning, assembly, conversion and commissioning thanks to system compatibility.

Better – by being quick to translate market trends into products. In this way, our innovative strength helps you to secure competitive advantages.

Worldwide – thanks to global networking across 150 locations. Rittal has over 60 subsidiaries, more than 250 service partners and over 1,000 service engineers worldwide. For more than 50 years, we have been on hand to offer advice, assistance and product solutions.

IT INFRASTRUCTURE

SOFTWARE & SERVICES



Rittal – The System.

Faster – better – worldwide.

RiMatrix S

The first mass-produced data centre

At a glance from page 26
Buildings from page 28
Security rooms from page 29
Containers from page 30

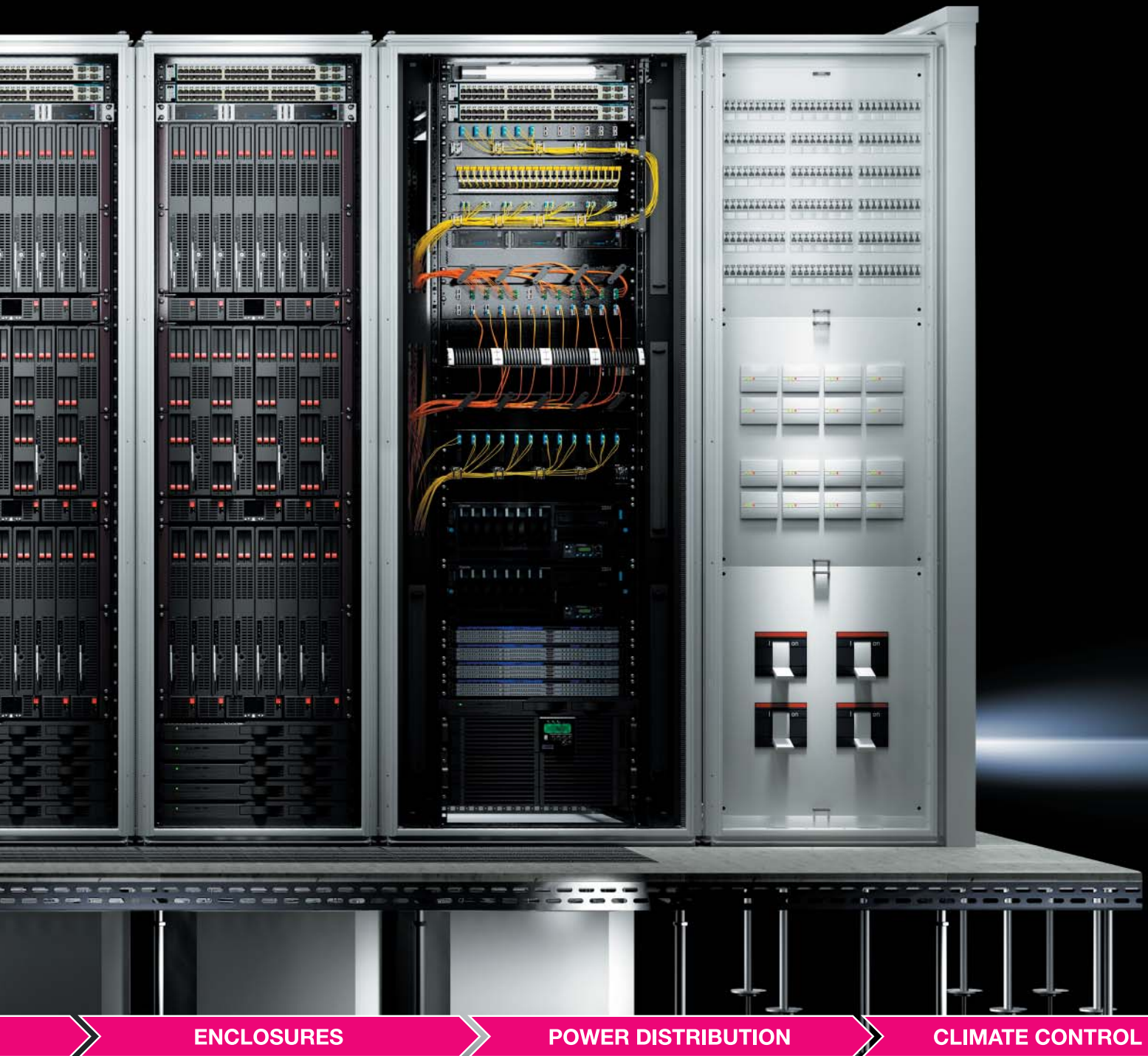

ENCLOSURES

POWER DISTRIBUTION

CLIMATE CONTROL

FRIEDHELM LOH GROUP

RiMatrix

The system for individual IT solutions



Liquid Cooling Package from page 32
Security safes from page 50
Security rooms from page 70

Other system products like rack, power, cooling, monitoring and security can be found in Catalogue 33 from page 489, in the TS IT brochure and on the Internet at www.rittal.com.

IT INFRASTRUCTURE

SOFTWARE & SERVICES



Rittal – The System.

Faster – better – worldwide.



ENCLOSURES

POWER DISTRIBUTION

CLIMATE CONTROL

FRIEDHELM LOH GROUP

We set standards – RiMatrix S.

Rittal opens up brand new perspectives for the IT world.

- Standardised, mass-produced data centre modules
- Only one item number
- Fully functional including server and network racks, climate control, power distribution and back-up, monitoring and DCIM (Data Center Infrastructure Management)
- Available for immediate delivery

The revolutionary alternative to individual data centre construction:
RiMatrix S



IT INFRASTRUCTURE

SOFTWARE & SERVICES



Rittal – The System.

Faster – better – worldwide.

Advice and decision-making

RiMatrix S is based on ingenious data centre modules with defined interfaces for power, cooling and monitoring, dimensions and functions. This considerably reduces the amount of planning work required:

- Simple selection of the required modules
- Fast integration into an existing supply infrastructure
- Complete ROI calculation including planning expenditure, investments, operating costs, personnel and servicing
- Defined parameters for scalability, availability, efficiency and performance
- Data centre automation through monitoring and controlling

For you, this translates into a host of benefits in terms of investments, operating costs, future-proofness and scalability.



Advice

Decision

ENCLOSURES

POWER DISTRIBUTION

CLIMATE CONTROL

Faster.

Delivery and commissioning

All data centre modules are pre-manufactured, available ex works, and designed for rapid configuration of a customised solution:

- Short delivery times
- Very fast commissioning
- Complete documentation of the data centre module at the time of handover
- Simplified final certification of the ready-to-use data centre at the customer's premises



Delivery

Commissioning

IT INFRASTRUCTURE

SOFTWARE & SERVICES





ENCLOSURES

POWER DISTRIBUTION

CLIMATE CONTROL

FRIEDHELM LOH GROUP

Better.

RiMatrix S provides peace of mind, thanks to:

- Reduced complexity
- Tested, quality-verified components
- Defined, monitored production processes
- Documented system test of the entire data centre module

For you as the user, this translates into:

- Low investment costs
- PUE (Power Usage Effectiveness) up to 1.15
- Tested characteristic curves and data sheets
- Precertification of the data centre modules by TÜV Rheinland

in Kooperation mit



TÜVRheinland[®]
Genau. Richtig.

IT INFRASTRUCTURE

SOFTWARE & SERVICES



Rittal – The System.

Faster – better – worldwide.



ENCLOSURES

POWER DISTRIBUTION

CLIMATE CONTROL

FRIEDHELM LOH GROUP

Worldwide.

The RiMatrix S modules are disengaged from the physical cover and defined infrastructure interfaces, which makes them extremely flexible.

For you as the user, this translates into:

- Simple integration into new or existing rooms with hot or cold aisle containment
- Installation in system-tested security rooms ...
- ... or as a flexible container solution
- Standardised modules for simplified worldwide delivery
- Commissioning by our 1,000 international service engineers



IT INFRASTRUCTURE

SOFTWARE & SERVICES



Rittal – The System.

Faster – better – worldwide.

RiMatrix S Single 6/Double 6

- Space-saving climate control in the raised floor
- Two separate, optimised climate zones for the server and technical area
- Consistent separation of cold air intake and warmer exhaust air integrated into the mechanical concept
- Cable routes at the top
- 6 server racks, 1 network rack
- UPS, battery rack and distribution enclosure
- In the Double 6, the second module is a mirror image

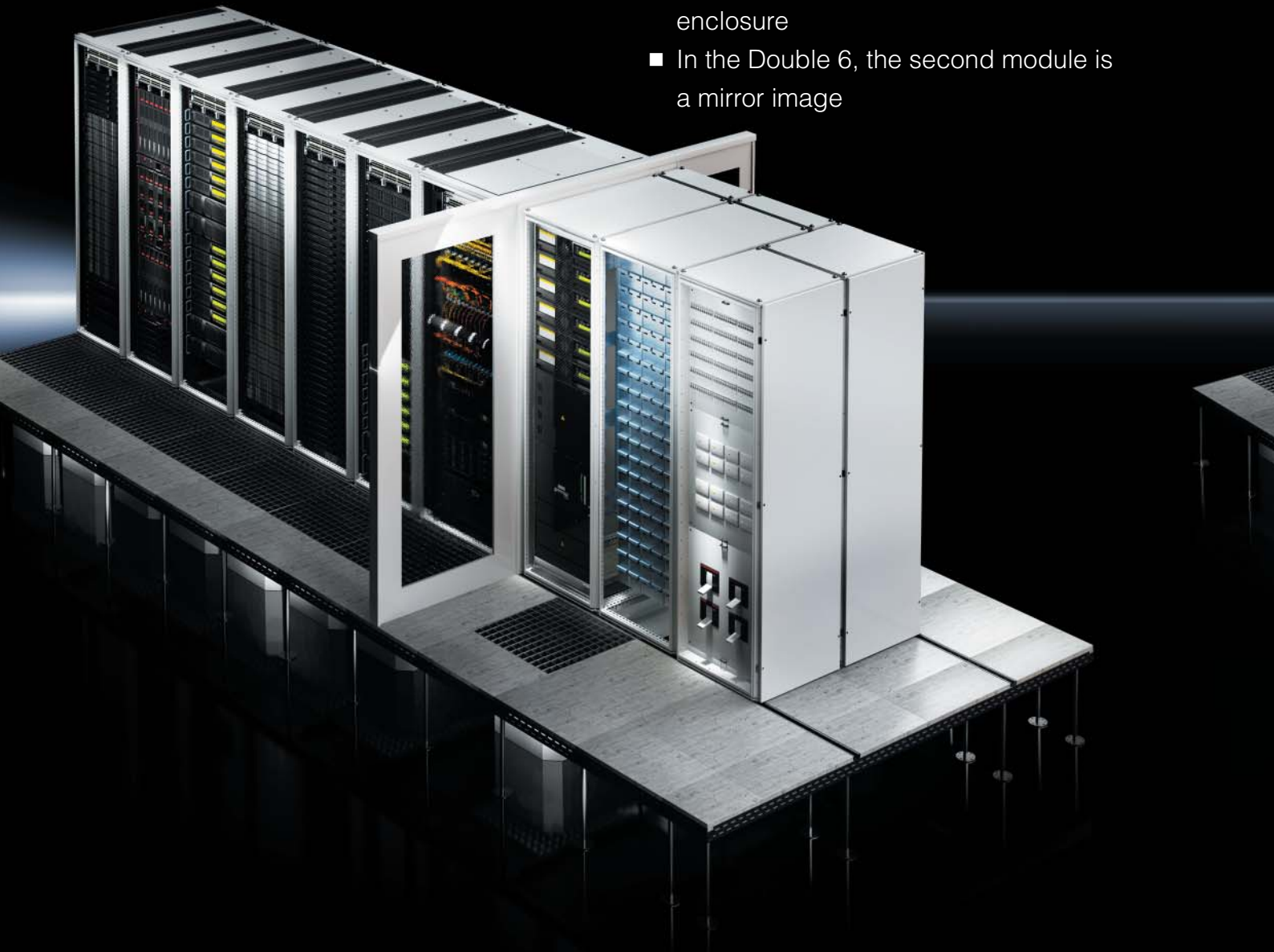

ENCLOSURES

POWER DISTRIBUTION

CLIMATE CONTROL

FRIEDHELM LOH GROUP

The system.

RiMatrix S data centre modules are ready to use immediately. Depending on whether there is a central UPS infrastructure available, the modules RiMatrix S Single 6/Double 6 or RiMatrix S Single 9/Double 9 are used.

RiMatrix S Single 9/Double 9

- When using a central UPS
- One climate zone for the server area
- Aisle containment
- Raised floor
- Climate control in the raised floor
- Cable routes at the top
- 8 server racks, 1 network rack
- Distribution enclosure
- In the Double 9, the second module is a mirror image



IT INFRASTRUCTURE

SOFTWARE & SERVICES



Rittal – The System.

Faster – better – worldwide.

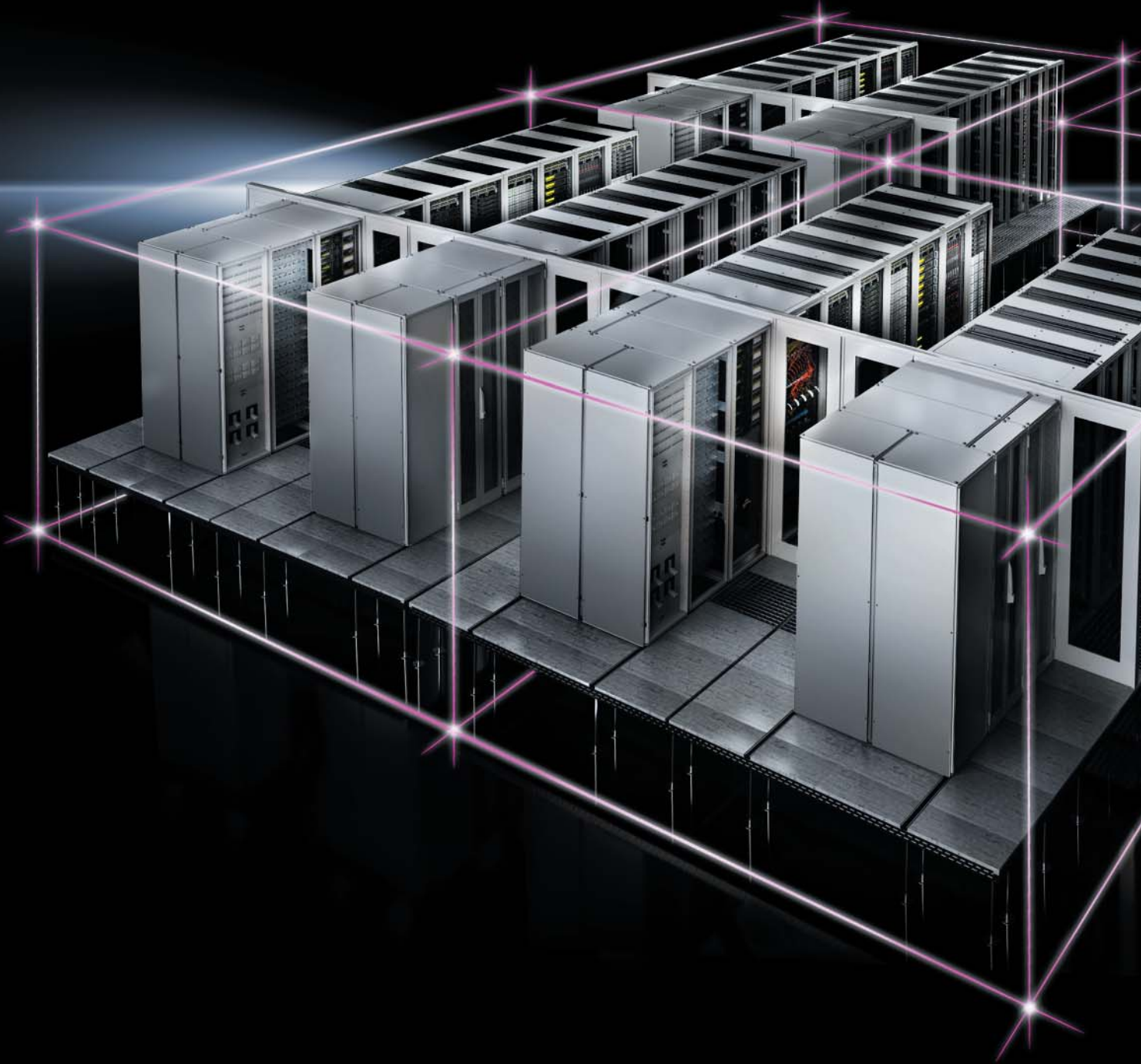

ENCLOSURES

POWER DISTRIBUTION

CLIMATE CONTROL

FRIEDHELM LOH GROUP

Make IT easy.

All Rimatrix S modules may be scaled to almost any output between 60 and 450 kW. Only the container solution is limited to scaling with the Single 6/Single 9 modules, due to the spatial conditions inside the containers.



Examples:

- Simple assembly of chessboard-like structures
- Parallel or serial arrangement
- Shared cold aisle and/or hot aisle
- Simple connection to supply infrastructures

IT INFRASTRUCTURE

SOFTWARE & SERVICES



Rittal – The System.

Faster – better – worldwide.



ENCLOSURES

POWER DISTRIBUTION

CLIMATE CONTROL

FRIEDHELM LOH GROUP

System accessories – Rack/Cooling.

- Space-saving climate control in the raised floor
- n+1 redundancy in climate control
- Simple air routing with high energy efficiency
- TS IT racks with 482.6 mm (19") frame, including compartmentalisation for consistent separation of hot and cold zones
- TS IT accessories may be installed without the need for tools
- Rack depth 1,200 mm, installation height 42 U



IT INFRASTRUCTURE

SOFTWARE & SERVICES



Rittal – The System.

Faster – better – worldwide.



ENCLOSURES

POWER DISTRIBUTION

CLIMATE CONTROL

FRIEDHELM LOH GROUP

System accessories – Cooling.

ZUCS (Zero U-Space Cooling Systems) are provided for climate control, so that no installation space for servers is lost.

- The heat exchangers are located beneath the racks.
- The heat exchanger connection is easily accessible via the raised floor behind the racks.
- The n+1 redundancy allows a high level of availability, i.e. even if one ZUCS should fail, the required cooling output is still provided.
- EC fans ensure a low energy consumption, and the system is dimensioned to enable operation in energy-saving part-load mode.
- The fans are arranged in front of the server racks in the raised floor, in a maintenance-friendly configuration.
- Intelligent air routing guarantees optimum operation.



IT INFRASTRUCTURE

SOFTWARE & SERVICES



Rittal – The System.

Faster – better – worldwide.



ENCLOSURES

POWER DISTRIBUTION

CLIMATE CONTROL

FRIEDHELM LOH GROUP

System accessories – Power.

- A modular UPS system is used for power back-up of the rack.
- The complete n+1 redundancy with consistent parallel architecture ensures a high degree of availability.
- The battery supports reliable shutdown of the servers or activation of a generator.
- The maximum load is 60 kW for the Single 6 module and 90 kW for the Single 9 module.
- All components may be monitored via the CMC III monitoring system and incorporated into the RiZone DCIM solution.



IT INFRASTRUCTURE

SOFTWARE & SERVICES



Rittal – The System.

Faster – better – worldwide.



ENCLOSURES

POWER DISTRIBUTION

CLIMATE CONTROL

FRIEDHELM LOH GROUP

System accessories – Monitoring.

- Monitoring of all relevant parameters with the CMC monitoring system such as temperature, humidity, leakage etc.
- Connection of security products, such as RAS systems
- Continuous monitoring and evaluation of operating states using the DCIM RiZone software
- Display of efficiency and consumption values of the active systems
- Intelligent workflows in the alarm management for optimisation and protection



IT INFRASTRUCTURE

SOFTWARE & SERVICES



RiMatrix S at a glance



	Building			
	Integration of the RiMatrix S modules into an existing property. In order to achieve optimum air routing, precise-fit aisle containment is included with the supply.		Aisle containment is a combination of door and roof components which allow consistent separation of the hot and cold air. <ul style="list-style-type: none"> - Enhanced energy efficiency - Superior output density, thanks to guaranteed cold air supply - Water- and dust-proof up to IP 20 - Double door optionally with door monitoring or electronic lock 	
	Single 6 basic cover	Double 6 basic cover	Single 9 basic cover	Double 9 basic cover
Model No.	7998.106	7998.107	7998.406	7998.407
Fire protection			-	
Burglar resistance			-	
Acrid gas-tightness			-	
Water and dust-tightness			IP 20	
Battery ventilation	■	■	-	-
Fire alarm system			■	
Room extinguisher system			Optional, extinguisher nozzle only in the area to be extinguished (complies with VDS)	
Humidification and dehumidification system			Optional package	
External dimensions				
Width mm	2828	4854	2828	4854
Height mm	2750	2750	2750	2750
Depth mm	7080	7080	7080	7080
Rack configuration				
Server rack (600 x 2000 x 1200 mm)	6	12	8	16
Combined network / server rack (800 x 2000 x 1200 mm)	1	2	1	2
Uninterruptible power supply	1 x PMC 120 60 kW + 20 kW	2 x PMC 120 2 x (60 kW + 20 kW)	-	-

RiMatrix S at a glance



Security rooms				Container	
LER Extend		Construction of the LER room systems		IT system container	
<ul style="list-style-type: none"> – Fire resistance EI 90 to EN 1363, system-tested – Dust- and watertight to IP 56 to IEC 60 529 – Protection from unauthorised access – Resistance class II – EMC basic protection – Flue gas-tightness based on EN 1634-3 – Shock test with 3,000 Nm energy after 30 minutes flame impingement over standard temperature curve 		<ul style="list-style-type: none"> – Element core made of thermally effective insulation substance – Robust, encapsulated sheet steel cassette panels – Innovative connection technology using patented profile technology – Use of temperature- and humidity-resistant seals – Use of fire protection valves – Dismantling and reassembly is possible at any time 		<p>Robust sheet steel container specifically designed for IT applications. The reinforced frame structure allows optimum weight distribution. Housed interior wall structure with thermal insulating materials.</p> <ul style="list-style-type: none"> – Vandal-resistant inner zone to resistance class II – Fire resistance EI 30 to EN 1363 – EMC basic protection – Dust- and watertight to IP 54 to IEC 60 529 	
Single 6 security room LER	Double 6 security room LER	Single 9 security room LER	Double 9 security room LER	Single 6 container	Single 9 container
7998.306	7998.307	7998.606	7998.607	7998.206	7998.506
EI 90 to EN 1363				EI 30 to EN 1363	
WK II				WK II	
Optional				–	■
IP 56		IP 56		IP 54	IP 54
■		–		■	none
■				■	
Optional, extinguisher nozzle only in the area to be extinguished (complies with VDS)				Optional, extinguisher nozzle only in the area to be extinguished (complies with VDS)	
–				Optional	
2950	4974	2950	4974	3000	3000
2800	2800	2800	2800	3000	3000
7500	7500	7500	7500	7250	7250
6	12	8	16	6	8
1	2	1	2	1	1
1 x PMC 120 60 kW + 20 kW	2 x PMC 120 2 x (60 kW + 20 kW)	none	none	1 x PMC 120 60 kW + 20 kW	none

Building



The RiMatrix S solution, including the basic cover, is commissioned at your premises and tested in accordance with our guidelines. The supply includes complete technical documentation of all components and works, together with the relevant user manuals.

We can optionally supply the relevant chapters of an operating and emergency manual.

Our services include:

- Advice and ROI calculation
- Delivery and integration into the customer infrastructure
- Commissioning and handover
- Documentation, training and instruction
- Hotline and service/service agreements
- Optional packages: Efficiency package, redundant infeed, extinguisher system ...

		Single 6 basic cover	Double 6 basic cover	Single 9 basic cover	Double 9 basic cover
External dimensions mm	Width	2828	4854	2828	4854
	Height	2750	2750	2750	2750
	Depth	7080	7080	7080	7080
Internal dimensions mm	Width	2750	4774	2750	4774
	Height	2700	2700	2700	2700
	Depth	7000	7000	7000	7000
Model No.		7998.106	7998.107	7998.406	7998.407
Physical security					
Fire protection					–
Burglar resistance					–
Acrid gas-tightness					–
Water and dust-tightness					IP 20
Battery ventilation		■	■	–	–
Fire alarm system				■	
Room extinguisher system		Optional, extinguisher nozzle only in the area to be extinguished (complies with VDS)			
Infrastructure					
Server rack (600 x 2000 x 1200 mm)		6	12	8	16
Combined network / server rack (800 x 2000 x 1200 mm)		1	2	1	2
Uninterruptible power supply		1 x PMC 120 60 kW + 20 kW	2 x PMC 120 2 x (60 kW + 20 kW)	–	–
Redundancy		1 x 20 kW	2 x 20 kW	–	–
Low-voltage main distributor		1	2	1	2
PDU Basic		14	28	18	36
Climate control (ZUCS)		(5 + 1) + 1	14	8 + 1	18
Redundancy		n+1			



The security rooms offer high-quality, system-tested solutions. This means that system-tested products are tested as a complete structure, taking into account the interactions between all components.

During testing, allowance is made for built-in modules such as doors, cable shielding systems and ventilation units. Benefit from multifunctional risk coverage (fire, water, burglary etc.) and compliance with the latest EN and DIN standards.

Our services include:

- Advice and ROI calculation
- Delivery and integration into the customer infrastructure
- Commissioning and handover
- Documentation, training and instruction
- Hotline and service/service agreements
- Optional packages: Efficiency package, redundant infeed, extinguisher system ...

	Single 6 security room LER	Double 6 security room LER	Single 9 security room LER	Double 9 security room LER	
External dimensions mm	Width	2950	4974	2950	4974
	Height	2800	2800	2800	2800
	Depth	7500	7500	7500	7500
Internal dimensions mm	Width	2750	4774	2750	4774
	Height	2700	2700	2700	2700
	Depth	7300	7300	7300	7300
Model No.	7998.306	7998.307	7998.606	7998.607	
Physical security					
Fire protection	F90 to DIN 4102				
Burglar resistance	WK II				
Acrid gas-tightness	Optional				
Water and dust-tightness	IP 20		IP 56		
Battery ventilation	■		-		
Fire alarm system	■				
Room extinguisher system	Optional, extinguisher nozzle only in the area to be extinguished (complies with VDS)				
Infrastructure					
Server rack (600 x 2000 x 1200 mm)	6	12	8	16	
Combined network / server rack (800 x 2000 x 1200 mm)	1	2	1	2	
Uninterruptible power supply	1 x PMC 120 60 kW + 20 kW	2 x PMC 120 2 x (60 kW + 20 kW)	-	-	
Redundancy	1 x 20 kW	2 x 20 kW	-	-	
Low-voltage main distributor	1	2	1	2	
PDU Basic	14	28	18	36	
Climate control (ZUCS)	(5 + 1) + 1	14	8 + 1	18	
Redundancy	n+1				

Container



The RiMatrix S solution is assembled in the container, then commissioned and tested in accordance with our guidelines. The supply includes complete technical documentation of all components and works, together with the relevant user manuals.

We can optionally supply the relevant chapters of an operating and emergency manual.

Our services include:

- Advice and ROI calculation
- Delivery and integration into the customer infrastructure
- Commissioning and handover
- Documentation, training and instruction
- Hotline and service/service agreements
- Optional packages: Efficiency package, redundant infeed, extinguisher system ...

		Single 6 container	Single 9 container
External dimensions mm	Width	3000	3000
	Height	3000	3000
	Depth	7250	7250
Internal dimensions mm	Width	2750	2750
	Height	2700	2700
	Depth	7000	7000
Model No.		7998.206	7998.506
Physical security			
Fire protection			–
Burglar resistance			–
Acrid gas-tightness		–	■
Water and dust-tightness		IP 54	IP 56
Battery ventilation		■	–
Fire alarm system			■
Room extinguisher system		Optional, extinguisher nozzle only in the area to be extinguished (complies with VDS)	
Infrastructure			
Server rack (600 x 2000 x 1200 mm)		6	8
Combined network / server rack (800 x 2000 x 1200 mm)		1	1
Uninterruptible power supply		1 x PMC 120 60 kW + 20 kW	–
Redundancy		1 x 20 kW	–
Low-voltage main distributor		1	2
PDU Basic		14	18
Climate control (ZUCS)		(5 + 1) + 1	8 + 1
Redundancy			n+1

Rittal – The System.

Faster – better – worldwide.



**The first mass-produced data centre.
Simply plug in and it's ready to use.**

Rittal – The System.

Faster – better – worldwide.

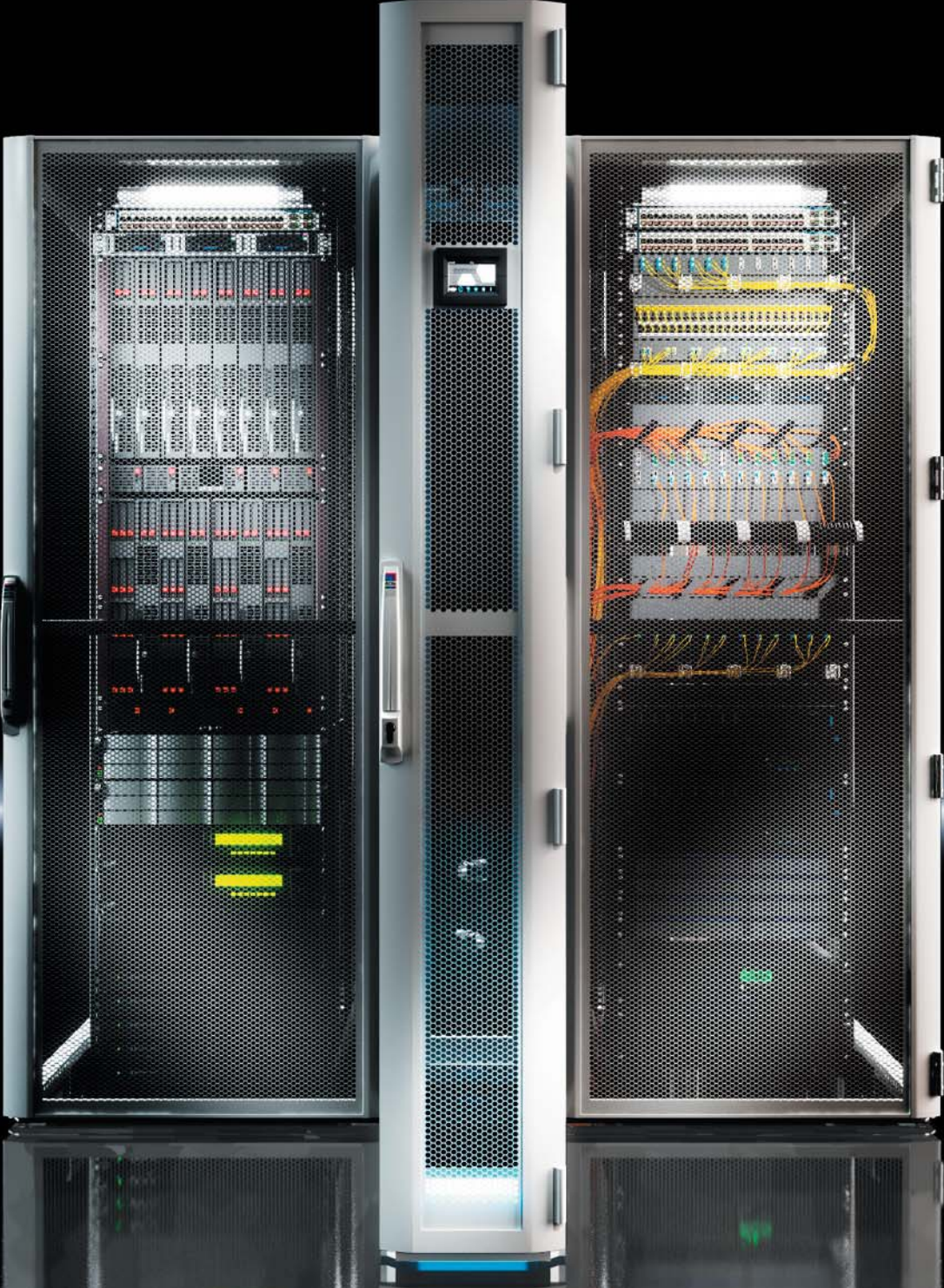

ENCLOSURES

POWER DISTRIBUTION

CLIMATE CONTROL

FRIEDHELM LOH GROUP

IT cooling. Liquid Cooling Package LCP.

High efficiency with optimum performance

Climate control of your data centre is particularly vital in terms of availability and energy costs. With the special Rittal liquid cooling concepts, we develop and implement high-efficiency climate control solutions on your behalf. Thanks to their intelligent control and the option of flexible expansion with additional fans, these can offer energy savings of up to 50%. This translates into savings with rack- and suite-based cooling solutions, both in terms of investments costs as well as energy and operating costs. You also help to protect the environment with resource and CO₂ savings.

Contents

IT cooling.	Page 34	Water-based fanless cooling solution	Page 42
Better.	Page 36	LCP – Liquid Cooling Package CW	Page 43
Water-based cooling solution	Page 38	Accessories for LCP CW/DX	Page 48
Coolant-based cooling solution	Page 40		

Rittal – The System.

Faster – better – worldwide.

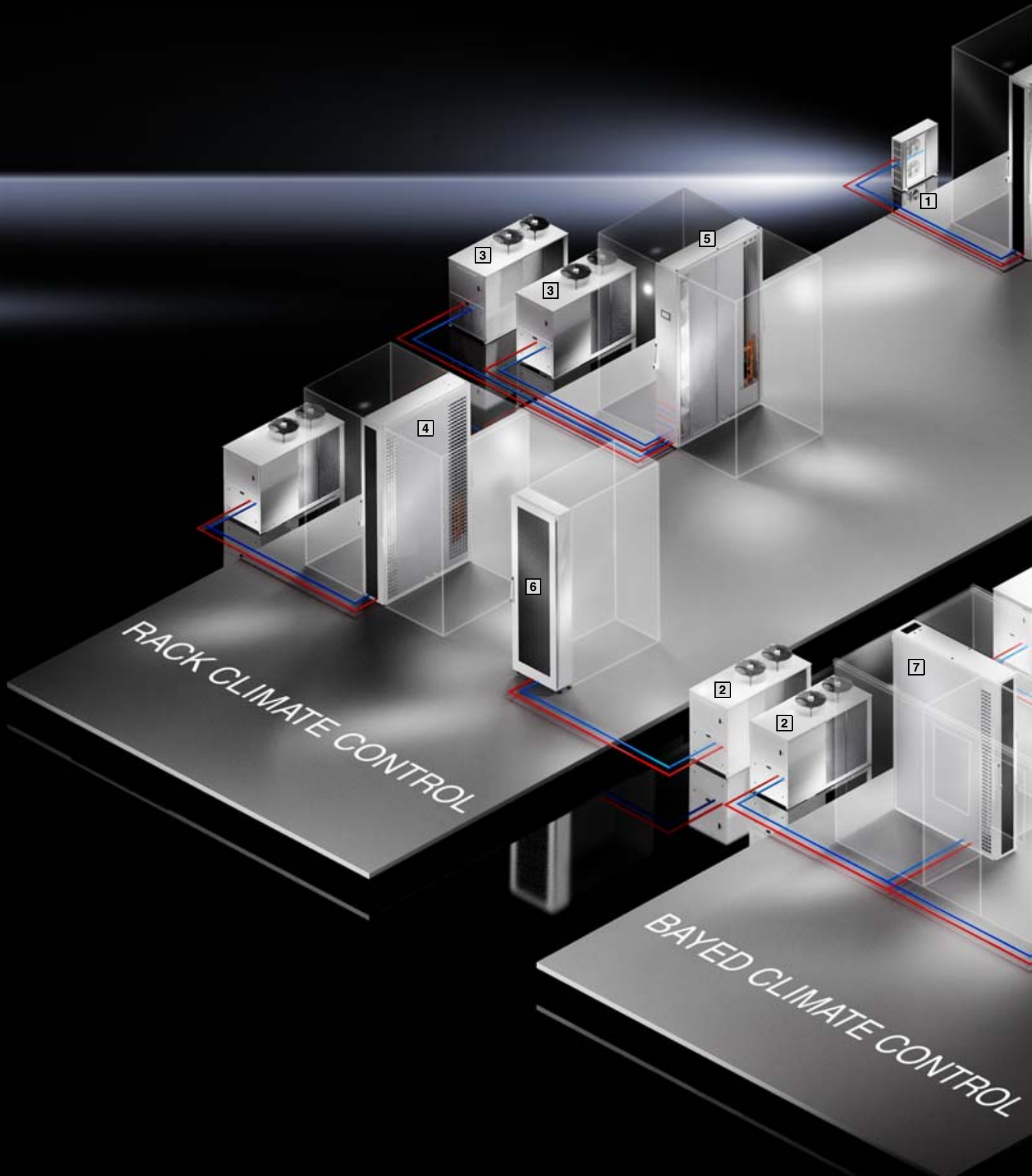

ENCLOSURES

POWER DISTRIBUTION

CLIMATE CONTROL

IT cooling.

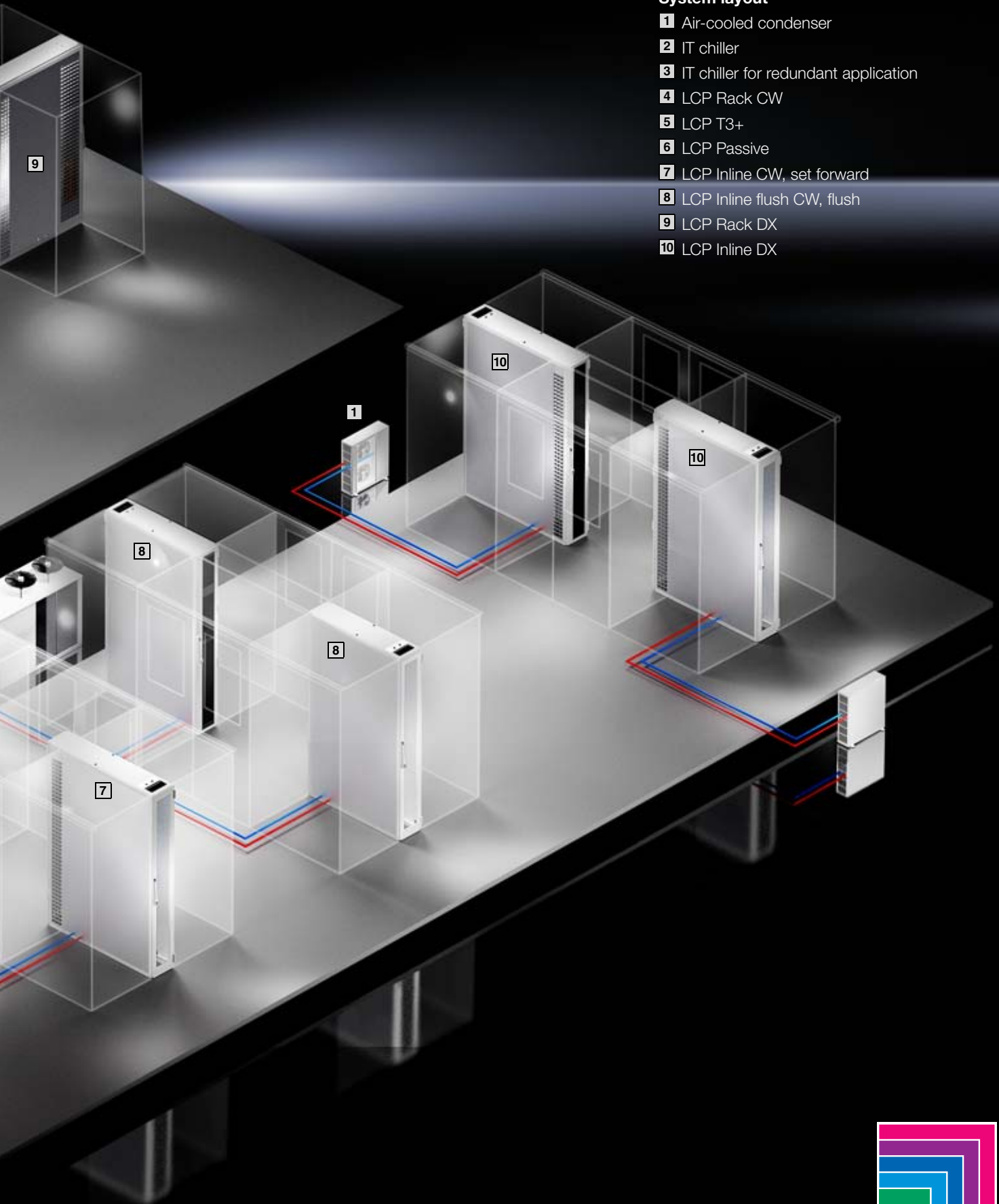

System layout

- 1** Air-cooled condenser
- 2** IT chiller
- 3** IT chiller for redundant application
- 4** LCP Rack CW
- 5** LCP T3+
- 6** LCP Passive
- 7** LCP Inline CW, set forward
- 8** LCP Inline flush CW, flush
- 9** LCP Rack DX
- 10** LCP Inline DX

IT INFRASTRUCTURE

SOFTWARE & SERVICES



Rittal – The System.

Faster – better – worldwide.

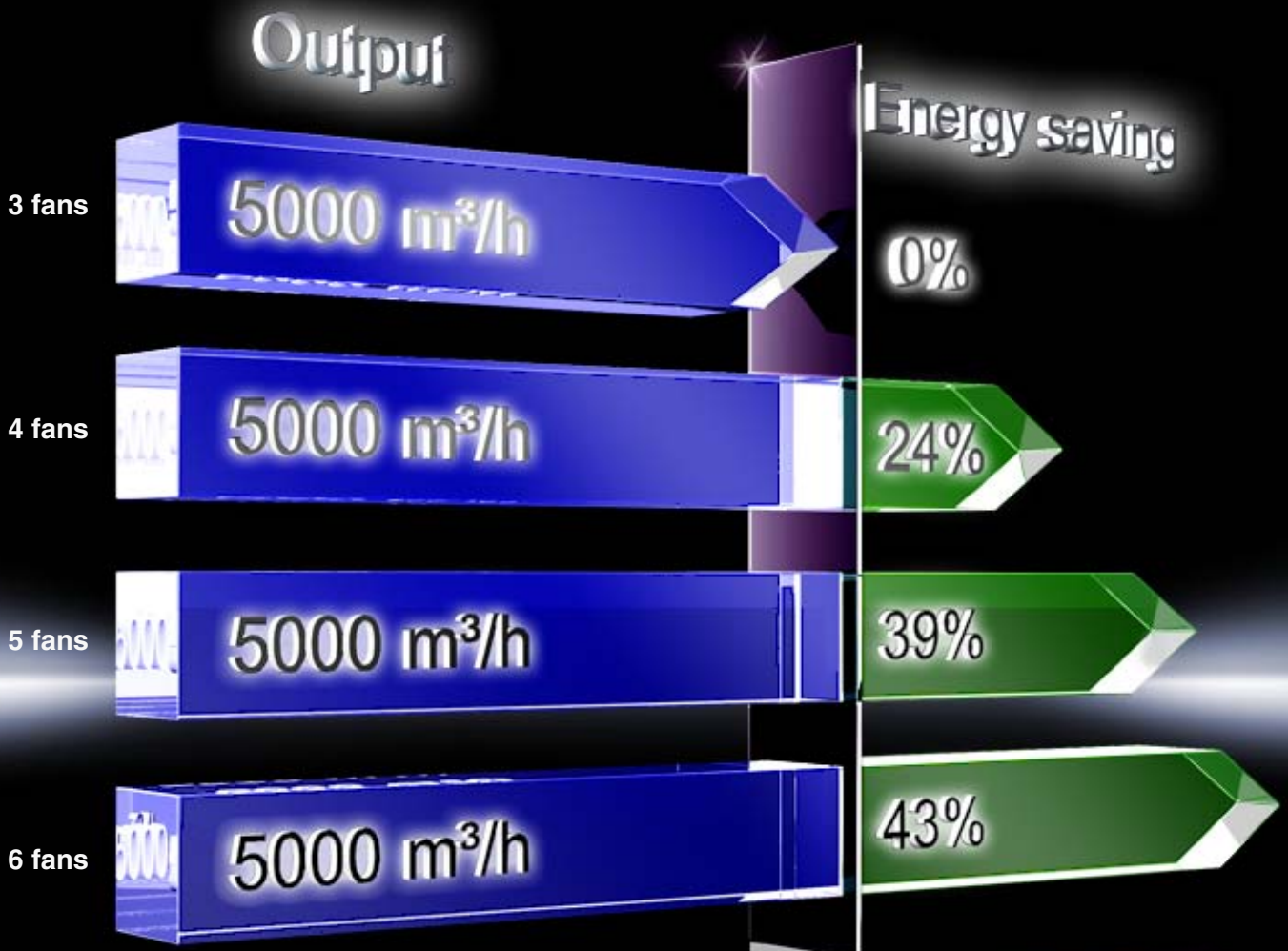

ENCLOSURES

POWER DISTRIBUTION

CLIMATE CONTROL

Better.



Easily achieve 50% energy savings!
Thanks to intelligent control and flexible configuration with additional fans, energy savings of up to 50% are easily achieved with the new LCP generation, at the same volumetric flow and constant cooling output.

- Identical volumetric flow with 3 – 6 fans
- Reduced noise levels with lower speeds
- Short amortisation period

IT INFRASTRUCTURE

SOFTWARE & SERVICES



Water-based cooling solution

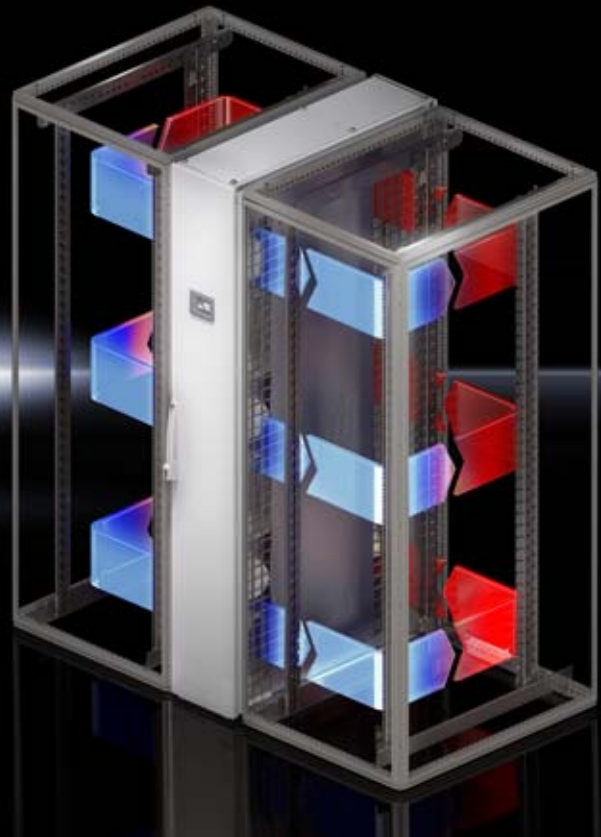

Rack cooling

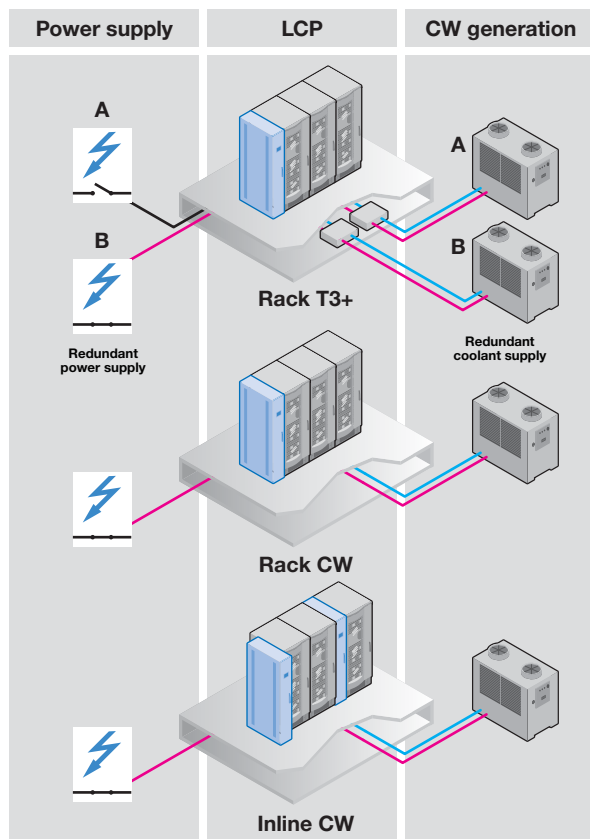

Data centres support corporate processes at ever-higher outputs. The packing density in computer systems is increasing, and processor capacity is growing. This leads to a continuous rise in heat development. Keep temperatures at a constant level with the highly efficient Rittal Liquid Cooling Packages (LCP). With optimised operating costs, our LCPs precisely and effortlessly dissipate heat losses of up to 24 kW per enclosure.

LCP Rack T3+, CW

- Redundant heat exchanger unit with two active water circuits (A/B medium supply)
- Redundant power infeed (A/B power supply) with automatic changeover in case of an emergency
- Fully redundant cooling output of 24 kW
- Redundant fan design
- Integrated controller with its own web server for network and BMS interfaces
- Auto-load balancing function
- Auto-recovery function
- Energy saving with high water inlet temperatures (more free cooling)
- Minimised operating costs with efficient EC fan technology
- Integration into RiZone (data centre management software)

Water-based cooling solution

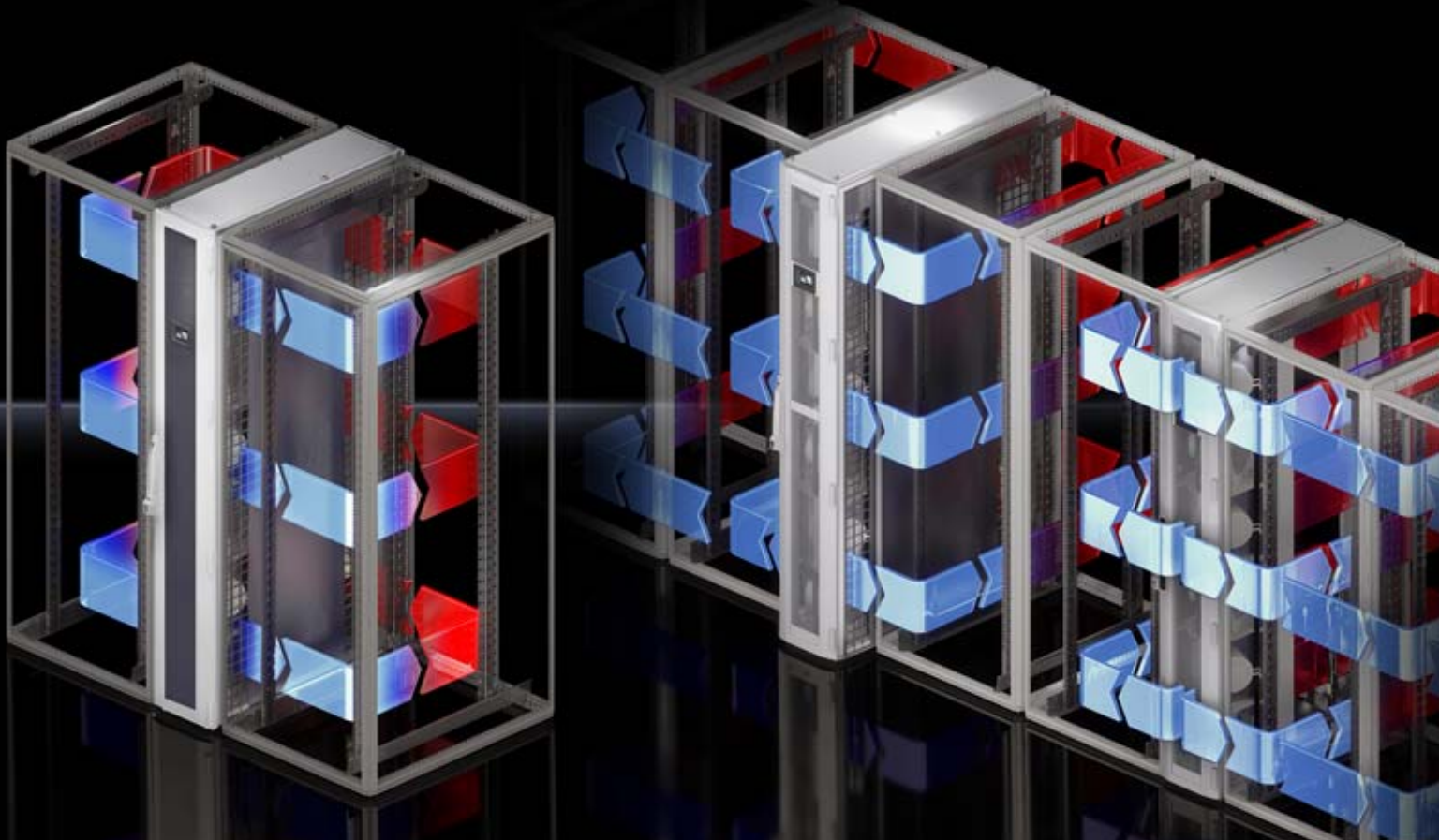

Rack cooling	Suite cooling
<p>Data centres support corporate processes at ever-higher outputs. The packing density in computer systems is increasing, and processor capacity is growing. This leads to a continuous rise in heat development. Keep temperatures at a constant level with the highly efficient Rittal Liquid Cooling Packages (LCP). With optimised operating costs, our LCPs precisely and effortlessly dissipate heat losses of up to 55 kW per enclosure.</p>	<p>Bayed suite cooling with the Rittal LCP Inline is extremely powerful, and the ideal climate control solution for exceptionally high cooling demands, particularly when the cooling of server racks cannot be achieved via the room climate control. Alternatively, bayed suite cooling can be used to support the existing climate control system in the room or for transforming existing structures into server rooms. A raised floor is not necessary for the operation of suite cooling.</p>
<p>LCP Rack CW</p> <ul style="list-style-type: none"> ■ Cooling output from 10 kW to 55 kW ■ Energy saving with high water inlet temperatures (more free cooling) ■ Minimised operating costs with efficient EC fan technology ■ Spatial separation of cooling and server rack ■ Integral condensate and leakage management ■ Sophisticated control concept including online connection ■ Optional cooling of one or two server racks ■ Simple representation of redundancies ■ Assembly- and service-friendly ■ Integration into RiZone (data centre management software) 	<p>LCP Inline CW</p> <ul style="list-style-type: none"> ■ Cooling output from 10 kW to 55 kW ■ Cooling of several server racks ■ Energy saving with high water inlet temperatures (more free cooling) ■ Minimised operating costs with efficient EC fan technology ■ Spatial separation of cooling and server rack ■ Integral condensate and leakage management ■ Sophisticated control concept including online connection ■ Assembly- and service-friendly ■ Optional front cover to reduce the air outlet speed and for superior air distribution ■ Increased performance and efficiency in conjunction with Rittal aisle containment ■ Integration into RiZone (data centre management software) ■ Variant set forward for ideal air distribution (cold air curtain) ■ Flush variant for confined spaces (narrow cold aisle)

Coolant-based cooling solution

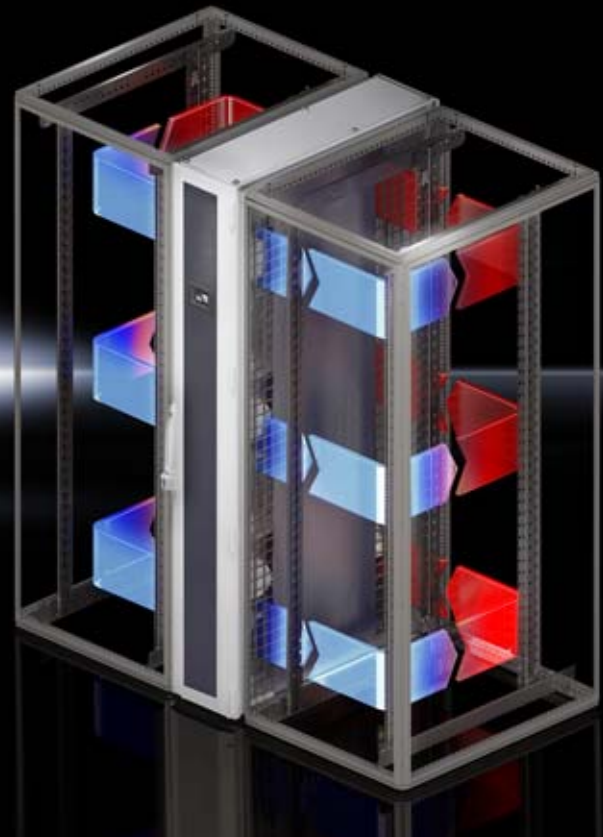

Rack cooling

Whether rack-based cooling of one or two server racks, or suite cooling with aisle containment. LCP Rack DX or LCP Inline DX are the ideal cooling solution for small to medium-sized IT installations. In particular, the stand-alone IT application is easily cooled with these devices.

Whereas in the past, cooling of stand-alone IT applications led to difficulties with conventional ceilings or air-conditioning units, the LCP DX devices support IT-compatible cooling. For retrofitting or exchanges, the existing coolant pipework can often be reused.

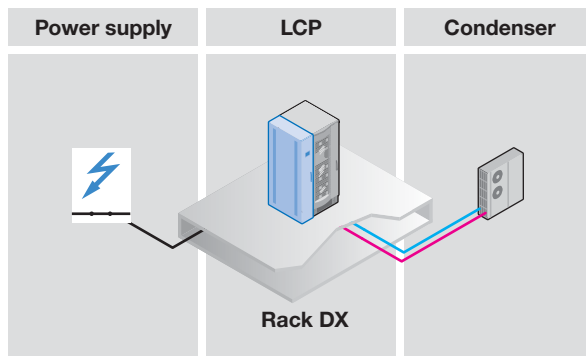

LCP Rack DX

- Cooling output 12 kW
- Refrigerant R410a
- Minimised operating costs with efficient EC fan technology
- Spatial separation of cooling and server rack
- Integral condensate and leakage management
- Sophisticated control concept including online connection
- Optional cooling of one or two server racks
- Simple representation of redundancies
- Assembly- and service-friendly
- Integration into RiZone (data centre management software)
- Cost-effective installation by laying small-diameter coolant lines

Coolant-based cooling solution

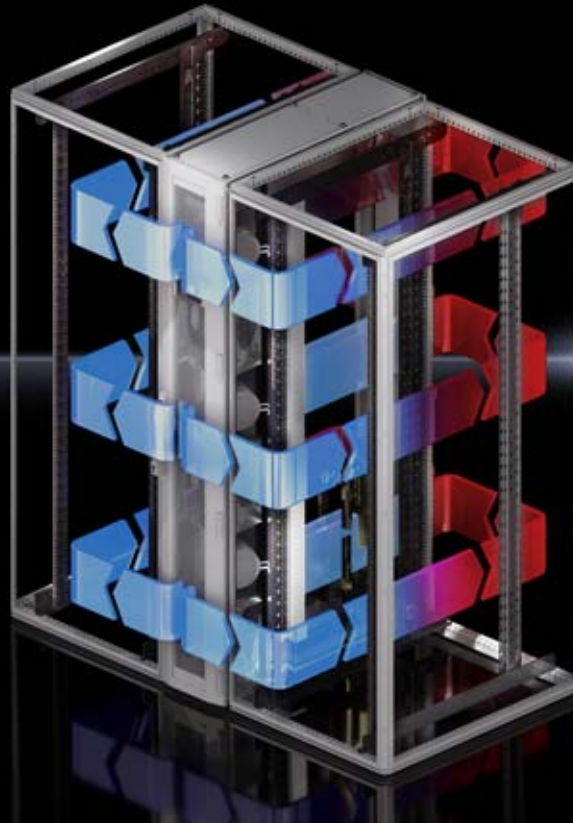

Suite cooling

Whether rack-based cooling of one or two server racks, or suite cooling with aisle containment, LCP Rack DX and LCP Inline DX are the ideal cooling solution for small to medium-sized IT installations. In particular, the stand-alone IT application is easily cooled with these devices.

Whereas in the past, cooling of stand-alone IT applications led to difficulties with conventional ceilings or air-conditioning units, the LCP DX devices allow IT-compatible cooling. For retrofitting or exchanges, the existing coolant pipework can often be reused.

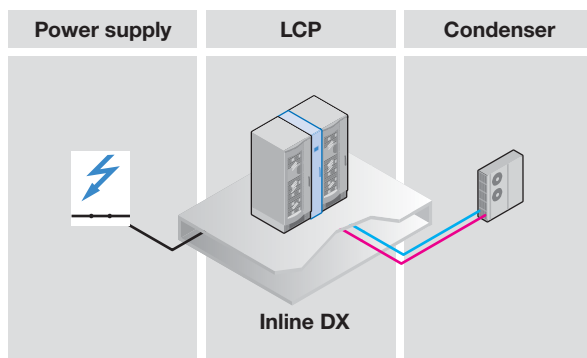

LCP Inline DX

- Cooling output 12 kW
- Cooling of several server racks
- Refrigerant R410a
- Minimised operating costs with efficient EC fan technology
- Spatial separation of cooling and server rack
- Integral condensate and leakage management
- Sophisticated control concept including online connection
- Assembly- and service-friendly
- Optional front cover to reduce the air outlet speed and for superior air distribution
- Increased performance and efficiency in conjunction with Rittal aisle containment
- Integration into RiZone (data centre management software)

Water-based fanless cooling solution

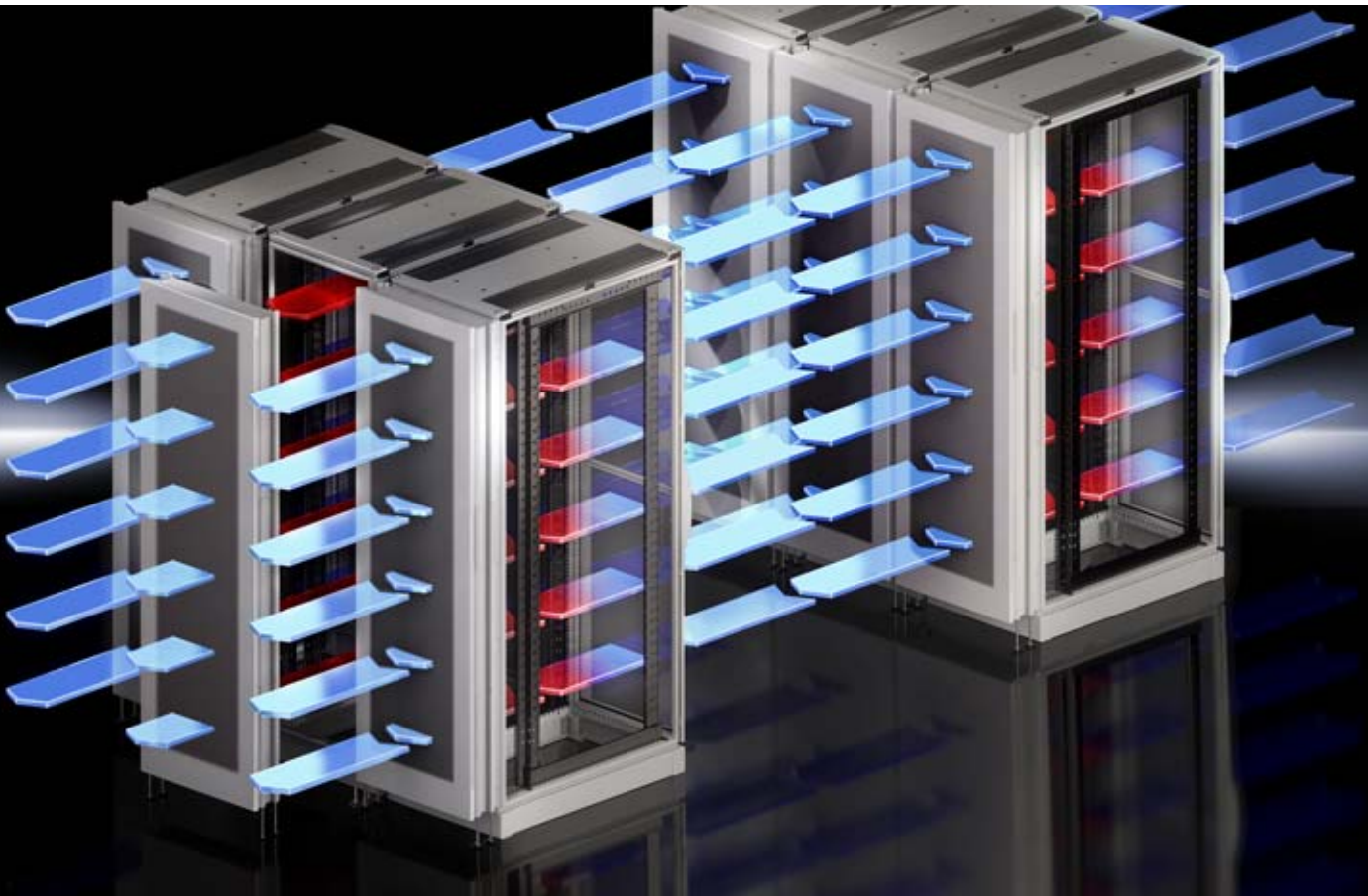

Rack cooling

The fans in the IT equipment independently guide the warm air over the high-capacity heat exchanger. The entire data centre functions as a cold aisle, and there is homogeneous temperature distribution. The LCP Passive creates a very large, effective heat exchanger surface area in the data centre which facilitates high water inlet temperatures and a high proportion of free cooling.

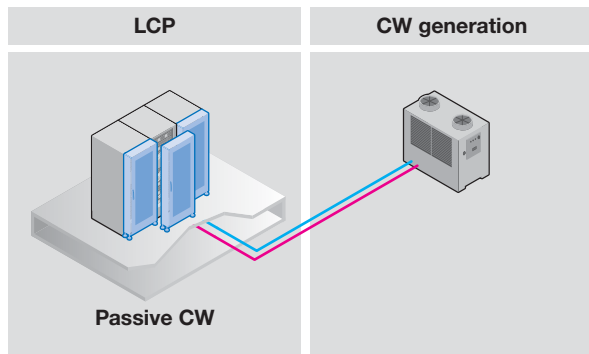

LCP Passive CW

- High cooling output of 20 kW in a minimal space
- Easily exchanged for the standard rear door of the server enclosure
- Retrofitting is not a problem
- A door opening angle of 120° allows rear access to the server enclosure and makes assembly and configuration inside the enclosure easier
- The LCP does not have its own fan, and therefore does not need an integrated control
- Maximum energy efficiency, as there is no electrical power consumption whatsoever

LCP – Liquid Cooling Package CW



Accessories from page 48

Benefits:

- Maximum energy efficiency thanks to EC fan technology and IT-based control
- Minimal pressure loss at the air end, which in turn minimises the power consumption of the fans
- Optimum adaptability thanks to dynamic, continuous control of the cold water volume flow
- Using high water inlet temperatures increases the proportion of indirect free cooling, which in turn reduces operating costs
- Targeted cooling output thanks to modular box-type plug-in fan units

- Box-type plug-in fan units configurable as n+1 redundancy
- Standard 3-phase connection for electrical redundancy
- With redundant temperature sensor integrated at the air end as standard
- The separation of cooling and rack prevents the ingress of water into the server enclosure
- Up to 55 kW cooling output on a footprint of just 0.36 m²
- Minimal area load thanks to low weight
- Touchscreen display may be retrofitted

Monitoring:

- Monitoring of all system-relevant parameters such as:
- Server air intake temperature
 - Server waste air temperature
 - Water inlet/return temperature
 - Water flow
 - Cooling output
 - Fan speed
 - Leakage
 - Optional sensors
 - Direct connection of the unit via SNMP over Ethernet
 - Integration into RiZone (data centre management software)

Application and mode of operation:

The LCP draws in the air at the sides at the rear of the server enclosures, cools it using high-performance compact impellers, and blows the cooled air back into the front part of the server enclosure at the sides.

Colour:

- RAL 7035
- Special colours available on request

Protection category:

- IP 40 to IEC 60 529

Technical information:

Available on the Internet.

Photo shows a configuration example with equipment not included in the scope of supply.

TopTherm LCP Rack CW

Cooling medium	Water (see Internet for specifications)											
Model No.	3311.130			3311.230			3311.260					
Variant in relation to rack suite	Flush			Flush			Flush					
Rated operating voltage V, Hz	230, 1~, 50/60, 400, 3~, 50/60			230, 1~, 50/60, 400, 3~, 50/60			230, 1~, 50/60, 400, 3~, 50/60					
Dimensions mm	W x H x D			300 x 2000 x 1000			300 x 2000 x 1200			300 x 2000 x 1200		
	Height 2200			On request			On request			On request		
No. of fans in supplied state	1			1			4					
Useful cooling output	10 kW	20 kW	30 kW	10 kW	20 kW	30 kW	40 kW	45 kW	55 kW			
Number of fans required	1	2	3	1	2	3	4	5	6			
Air throughput, max.	4800 m ³ /h with 3 fans			4800 m ³ /h with 3 fans			8000 m ³ /h with 6 fans					
Water inlet temperature	15 °C											
Permissible operating pressure	6 bar											
Duty cycle	100%											
Type of electrical connection	Connector											
Water connection	1 1/2" external thread											
Weight, max.	200 kg	207 kg	214 kg	200 kg	207 kg	214 kg	221 kg	228 kg	235 kg			
Temperature control	Linear fan control											
	Two-way control valve											
Fans may be exchanged with the system operational	yes			yes			yes					
EC fan	■			■			■					
Accessories	Packs of						Page					
Fan module	1	3311.010			3311.010			3311.010		49		
Touchscreen display, colour	1	3311.030			3311.030			3311.030		465 ¹⁾		
Connection hose, top	2	3311.040			3311.040			3311.040		465 ¹⁾		

■ Included with the supply. ¹⁾ See Catalogue 33.

LCP – Liquid Cooling Package CW



Accessories from page 48

Benefits:

- Maximum energy efficiency thanks to EC fan technology and IT-based control
- Minimal pressure loss at the air end, which in turn minimises the power consumption of the fans
- Optimum adaptability thanks to dynamic, continuous control of the cold water volume flow
- Using high water inlet temperatures increases the proportion of indirect free cooling, which in turn reduces operating costs
- Targeted cooling output thanks to modular box-type plug-in fan units
- Box-type plug-in fan units configurable as n+1 redundancy
- Standard 3-phase connection for electrical redundancy
- With redundant temperature sensor integrated at the air end as standard
- The separation of cooling and rack prevents the ingress of water into the server enclosure
- Up to 55 kW cooling output on a footprint of just 0.36 m²
- Minimal area load thanks to low weight
- Touchscreen display may be retrofitted

Monitoring:

- Monitoring of all system-relevant parameters such as:
- Server air intake temperature
 - Server waste air temperature
 - Water inlet/return temperature
 - Water flow
 - Cooling output
 - Fan speed
 - Leakage
 - Optional sensors
 - Direct connection of the unit via SNMP over Ethernet
 - Integration into RiZone (data centre management software)

Note:

- Height 2200 mm available on request.

Photo shows a configuration example with equipment not included in the scope of supply.

Application and mode of operation:

The LCP is designed for siting within a bayed enclosure suite. The hot air is drawn in from the room or hot aisle at the rear of the device and expelled at the front into the cold aisle after cooling. The LCP achieves maximum performance and efficiency in conjunction with aisle containment. A raised floor is not required.

Colour:

- RAL 7035
- Special colours available on request

Protection category:

- IP 40 to IEC 60 529

Technical information:

Available on the Internet.

TopTherm LCP Inline CW

Cooling medium	Water (see Internet for specifications)									
Model No.	3311.530			3311.540			3311.560			
Variant in relation to rack suite	Set forward			Flush			Set forward			
Rated operating voltage V, Hz	230, 1~, 50/60, 400, 3~, 50/60			230, 1~, 50/60, 400, 3~, 50/60			230, 1~, 50/60, 400, 3~, 50/60			
Dimensions mm	W x H x D 300 x 2000 x 1200			300 x 2000 x 1200			300 x 2000 x 1200			
No. of fans in supplied state	1			2			4			
Useful cooling output	10 kW	20 kW	30 kW	18 kW	25 kW	30 kW	40 kW	45 kW	55 kW	
Number of fans required	1	2	3	2	3	4	4	5	6	
Air throughput, max.	4800 m ³ /h with 3 fans			4800 m ³ /h with 3 fans			8000 m ³ /h with 6 fans			
Water inlet temperature	15 °C									
Permissible operating pressure	6 bar									
Duty cycle	100%									
Type of electrical connection	Connector									
Water connection	1 1/2" external thread									
Weight, max.	200 kg	207 kg	214 kg	207	213	221	221 kg	228 kg	235 kg	
Temperature control	Linear fan control									
	Two-way control valve									
Fans may be exchanged with the system operational	yes			yes			yes			
EC fan	■			■			■			
Accessories	Packs of						Page			
Fan module	1	3311.010			3311.010			3311.010		49
Touchscreen display, colour	1	3311.030			3311.030			3311.030		465 ¹⁾
Connection hose, top	2	3311.040			3311.040			3311.040		465 ¹⁾
Rear adaptor for LCP Inline	1	3311.080			-			3311.080		48

■ Included with the supply. ¹⁾ See Catalogue 33.

LCP – Liquid Cooling Package CW



Accessories from page 48

Benefits:

- Error-tolerant, efficient cooling of server racks with high thermal loads
- Fully redundant – Two active cooling circuits and two switchable power circuits ensure optimum fail-safeness
- The built-in controllers are capable of adapting all device parameters automatically to preserve the required climate conditions

- A separate decentralised intelligence which automatically recognises emergency situations and responds appropriately with the “auto-load balancing” and “auto-recovery” functions
- Interfaces which facilitate user-friendly operation and monitoring via the network or BSM systems

Optional:

- Fully integrated fire detection and extinguisher system
- Automatic server enclosure door opening
- Various sensors

Colour:

- RAL 7035

Protection category:

- IP 40 to IEC 60 529

Application and mode of operation:

The LCP draws in the air at the sides at the rear of the server enclosures, cools it using high-performance compact impellers, and blows the cooled air back into the front part of the server enclosures at the sides.

TopTherm LCP T3+ CW

Cooling medium	Water (see Internet for specifications)
Model No.	3300.239
Rated operating voltage V, Hz	230, 1-, 50/60 400, 3-, 50/60
Dimensions mm	W x H x D 300 x 2200 x 1200
Usable U	42
Useful cooling output, redundant	up to 20 kW
Duty cycle	100%
Type of electrical connection	C19/C20
Temperature control	Linear fan control Two-way control valve
Fans may be exchanged with the system operational	■
EC fan	■
Auto-load balancing	■
Auto-recovery	■

LCP – Liquid Cooling Package CW



Accessories from page 48

Benefits:

- High cooling output of 20 kW in a minimal space
- Easily exchanged for the standard rear door of the server enclosure
- Retrofitting is not a problem
- A door opening angle of 120° allows rear access to the server enclosure and makes assembly and configuration inside the enclosure easier

- The LCP does not have its own fan
- Maximum energy efficiency, as there is no electrical power consumption whatsoever

Application and mode of operation:

Air/water heat exchanger mechanically integrated into a rear door for server enclosures. The 482.6 mm (19") equipment built into the server enclosure must have suitable airflow capabilities in order to route the heated waste air through the heat exchanger rear door. The waste air is cooled down to room temperature. The heat energy absorbed by the water is transported to the external cold water supply, where it is cooled back down to the required inlet temperature.

Colour:

– RAL 7035

Approvals:

Available on the Internet.

TopTherm LCP Passive CW

Model No.		3311.600
Dimensions mm	W x H x D	600 x 2000 x 170
Usable U		42
Useful cooling output		up to 20 kW

LCP – Liquid Cooling Package DX



Accessories from page 48

Benefits:

- Maximum energy efficiency thanks to EC fan technology and IT-based control
- Minimal pressure loss at the air end, which in turn minimises the power consumption of the fans
- Control of the server inlet temperature
- Thanks to the speed-regulated compressor, the cooling output is ideally adapted to actual requirements
- With redundant temperature sensor integrated at the air end as standard

- Absorbed thermal energy is emitted to the ambient air at the external condenser location, without heating up the installation room
- Ideal for IT cooling in small and medium-sized locations
- Humidifier, reheater or condensate pump available on request
- Higher cooling outputs available on request
- Specific maintenance of the LCP DX thanks to separation of cooling and server rack

Functions of the LCP Rack DX:

The LCP draws in the air at the sides at the rear of the server enclosures, cools it using high-performance compact impellers, and blows the cooled air back into the front part of the server rack at the sides.

Functions of the LCP Inline DX:

The LCP is designed for siting within a bayed enclosure suite. Hot air is drawn in from the room or hot aisle at the rear of the device, cooled by the high-capacity compact impellers, and blown back into the room or cold aisle after cooling.

LCP Rack/Inline DX

Installation in bayed enclosure suite	Flush/Rack DX		Flush/Inline DX	
Cooling medium	R410a	R410a	R410a	R410a
Model No.	3311.410	3311.420	3311.430	3311.440
Rated operating voltage V, Hz	380 V AC, 3~, 50 480 V AC, 3~, 60	380 V AC, 3~, 50 480 V AC, 3~, 60	380 V AC, 3~, 50 480 V AC, 3~, 60	380 V AC, 3~, 50 480 V AC, 3~, 60
Dimensions mm	W x H x D	300 x 2000 x 1000	300 x 2000 x 1200	300 x 2000 x 1200
Number of fans	4	4	4	4
Air throughput of fans	4800 m ³ /h	4800 m ³ /h	4800 m ³ /h	4800 m ³ /h
Cooling output	12 kW	12 kW	12 kW	12 kW
Duty cycle %	100	100	100	100
Type of connection (electrical)	Connection clamp	Connection clamp	Connection clamp	Connection clamp
Fans may be exchanged with the system operational	■	■	■	■
EC fan	■	■	■	■
Colour	RAL 7035 Special colours available on request		RAL 7035 Special colours available on request	
Temperature control	Linear fan control Inverter-regulated compressor		Linear fan control Inverter-regulated compressor	
Accessories				
Condenser unit	3311.360		3311.360	
SNMP card	3311.320		3311.320	

■ Included with the supply.

Accessories for LCP CW/DX



Touchscreen display, colour

for LCP Rack, Inline, CW

The display offers the opportunity of directly monitoring key LCP functions and implementing settings.

For LCP CW	Packs of	Model No.
3311.130 3311.230 3311.260 3311.530 3311.540 3311.560	1	3311.030



Condenser unit

The condenser unit is needed to operate the coolant-based LCPs, and comprises the external condenser and fan. The pipework between the LCP DX and the condenser is not included with the supply.

Coolant:

- R410a

For LCP DX	Packs of	Model No.
3311.410 3311.420 3311.430 3311.440	1	3311.360



Vertical shielding

To block the airflow on the left and right of the 482.6 mm (19") level, for enclosure height 2000 mm.

Material:

- Cellular PU foam
- Flame-inhibiting to UL 94 (HF1)
- Length: 1900 mm
- Self-adhesive on one side

For sealing between	For enclosure width mm	Packs of	Model No.
Side panel and 482.6 mm (19") level	600	1	3301.380
	800	1	3301.390
LCP and 482.6 mm (19") level	600	1	3301.370
	800	1	3301.320



Connection hose, bottom and top

Flexible connection hose, may be cut to required length, including union nuts on both sides for connecting the LCP to existing pipework.

For LCP CW	Thread	Water connection from	Packs of	Model No.
3311.130 3311.230 3311.260 3311.530 3311.560	1 1/2"	bottom/top	2	3311.040



Rear adaptor

for LCP Inline

May be positioned to the rear of the set forward LCP Inline to close the existing gap in the rear section.

For LCP	Packs of	Model No.
3311.530 3311.560	1	3311.080

SNMP card

SNMP card as an accessory for connecting LCP Rack/Inline DX units to the network.

For LCP DX	Packs of	Model No.
3311.410 3311.420 3311.430 3311.440	1	3311.320

Accessories for LCP CW/DX

Fan module

for LCP

To increase the cooling output, individual fan modules may be retro-fitted into the LCPs. Additional integration can also achieve redundancy or reduce the electric power consumption of the LCPs.

For LCP	Packs of	Model No.
3311.130, 3311.230, 3311.260, 3311.530, 3311.560	1	3311.010

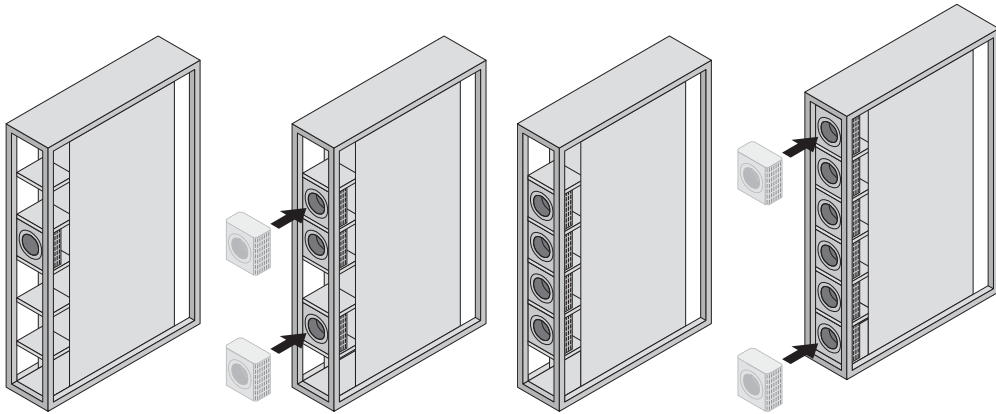

The LCP 3311.130/.230/.530 (max. 30 kW) is supplied with one fan module as standard.

To achieve the max. cooling output of 30 kW, the customer/service needs to install two additional fan modules.

The LCP 3311.260/.560 (max. 55 kW) is supplied with four fan modules as standard.

To achieve the max. cooling output of 55 kW, the customer/service needs to install two additional fan modules.



Fan module

for LCP

To increase the cooling output, individual fan modules may be retro-fitted into the LCPs. Additional integration can also achieve redundancy or reduce the electric power consumption of the LCPs.

For LCP	Packs of	Model No.
3311.540	1	3311.011

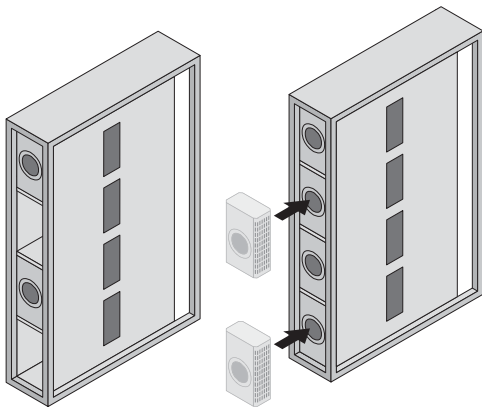

Supplied as standard with two fan modules.

To achieve the max. cooling output, the customer/service needs to install two additional fan modules.



Rittal – The System.

Faster – better – worldwide.



ENCLOSURES

POWER DISTRIBUTION

CLIMATE CONTROL

FRIEDHELM LOH GROUP

Security safe as a compact data centre.

Maximum protection in a minimal space

Rittal's portfolio contains the right protection concept for every business security requirement. Like security rooms, security safes provide optimum protection against potential physical threats to your IT applications. From Level A compact safes through to Level E modular safes, we have the perfect solution for your specific security requirements. The compact safes offer an optimum protection concept for small and medium-sized enterprises in particular, by providing a physical cover for individual server racks. Features such as modularity and extendibility guarantee investment security and flexibility, making them ideal for use in decentralised IT locations or for back-up applications in companies.

Contents

Security safe as a compact data centre.	Page 52	Compact split cooling solution	
Benefits of security safes	Page 54	for modular safes	Page 63
Overview of security safes	Page 56	Split outdoor cooling solution	
Level E modular safe	Page 58	for modular safes	Page 64
Options for level E modular safe	Page 59	Split outdoor cooling solution	
Level B modular safe	Page 60	with inverter technology	Page 65
Options for level B modular safe	Page 61	Fire alarm and extinguisher system	
Level A compact safe	Page 62	DET-AC/EFD Plus	Page 66
		CMC III monitoring system	Page 67
		Power distribution/supply	Page 68

Rittal – The System.

Faster – better – worldwide.



Security safe as a compact data centre.

In addition to the physical cover in the form of an IT security safe, the configuration components listed below complement the Rittal safe and transform it into a fully fitted compact data centre.

- Robust, flexible racks especially for server and network technology
- Efficient climate control solutions in a range of designs and outputs
- IT-specific power distribution
- Networkable monitoring and security solutions with the CMC III system
- Early fire detection and automatic rack extinguishing



Benefits of security safes



Level E modular safe	
<ul style="list-style-type: none"> ■ Complete solution in the smallest possible space and in next to no time ■ No need for expensive upgrades to existing premises ■ Efficient cooling and extinguishing solution 	<p>High level of protection for your IT</p> <ul style="list-style-type: none"> ■ Maximum security in the Rittal range of safes ■ Optimum protection concept for one or more server rack solutions for small and medium-sized enterprises ■ Modular layout for installation in hard-to-access locations and for retrospective enclosure of existing IT structures ■ Future-proof investment thanks to the options of extendibility, dismantling and re-assembly ■ System-tested security and a high level of protection; testing has been carried out by accredited institutes and confirmed with test reports ■ Modified air baffle plates for optimum air routing, for efficient cooling of the safes

Benefits of security safes



Level B modular safe

Solid protection for your IT

- Optimum protection concept for a server rack
- Modular layout for installation in hard-to-access locations
- Form-fit connection with the stable TS 8 framework structure
- Front and rear 482.6 mm (19") level of the TS IT rack already included with the supply
- Lower weight than the Level E modular safe
- Tested security – testing has been carried out by accredited institutes and confirmed with test reports.

Level A compact safe

Solid protection for small IT applications

- Ready-installed safe as a complete system
- Integral cooling
- Integral TS 8 frame structure with front and rear pairs of 482.6 mm (19") mounting angles
- Base/plinth with ground clearance
- Tested safety – The tests were carried out as system tests and confirmed via test reports

Overview of security safes



Requirement-based security	Level E modular safe	
Usable U	42/47	
Usable interior depth mm	1000/1200	
Colour of enclosure/service door	RAL 7035	
Colour of operator door	RAL 9005	
Fire protection	Fire resistance class F 90 to DIN 4102 Part 2, compliance with limits $\Delta T < 50$ K, rel. humidity $< 85\%$ over 30 minutes ¹⁾	
Burglar resistance	WK II tool attack analogous to DIN V ENV 1630/1999-04/WK II ⁴⁾ WK III tool attack analogous to DIN V ENV 1630/1999-04/WK II ³⁾ WK IV tool attack analogous to DIN V ENV 1630/1999-04/WK II ³⁾	
Protection category	IP 56 to IEC 60 529 ⁴⁾	
Smoke protection	Based on DIN 18 095-2: 1991-03 ⁴⁾	
Modularity	■	
May be enclosed with the system operational	■	
Extendibility	■	

¹⁾ The safe was tested as a system.

²⁾ The critical connection points were tested as a system.

³⁾ The single safe was tested as a system with single-leaf doors and mechanical lock.

⁴⁾ The single safe was tested as a system with one single-leaf door and one bifold door and mechanical lock.

Overview of security safes



	Level B modular safe	Level A compact safe
	42/47	15
	1000/1200	1000
	RAL 7035	RAL 7035
	RAL 9005	RAL 9005
	Fire resistance class EI 90/F 90 to DIN EN 1363-1: 1999 / based on DIN 4102-2:1997 ²⁾	Fire resistance class F 90 to DIN 4102 Part 2, compliance with limits $\Delta T < 50$ K, rel. humidity $< 85\%$ over 10 minutes ¹⁾
	RC 2 tool attack analogous to DIN EN 1630/2011-09/RC 2 ³⁾	WK II tool attack analogous to DIN V ENV 1630/1999-04/WK II ¹⁾
	IP 56 to IEC 60 529: 2000 ³⁾	IP 55 to IEC 60 529 ¹⁾
	Based on DIN EN 1634-3: 2005-01 ³⁾	–
	■	Safe is supplied assembled including cooling unit
	–	–
	–	–

Level E modular safe



Applications:

- A high level of protection against potential physical threats for IT
- Targeted configuration components transform the safe into a complete, compact data centre

Benefits:

- As well as facilitating installation in poorly accessible sites, the modular design also makes it possible to retrospectively enclose existing IT structures.
- Extensibility, dismantling and re-assembly mean targeted, future-safe investments.
- System-tested security and a high level of protection

Protection standards:

- Fire protection – fire resistance class F 90 to DIN 4102 Part 2
 - Compliance with limit values $\Delta T < 50$ K, relative humidity 85% for 30 minutes
 - Burglar resistance WK II, III and IV, tool attack analogous to DIN V ENV 1630/1999-04/ WK II
 - Protection category IP 56 to IEC 60 529
 - Smoke protection based on DIN 18 095-2: 1991-03
- The tests were performed as system tests and confirmed with test certificates.

Material:

- Sheet steel, coated

Colour:

- Enclosure and service door: RAL 7035
- Operator door: RAL 9005

Supply includes:

- Security safe with operator door and service door
- Cable entry in both side elements
- Both doors with key lock

Optional:

- Choice of door hinges
- Bifold doors
- Different cable entry systems
- Cable entry additionally in the top or base unit
- Different lock variants
- Supporting structure

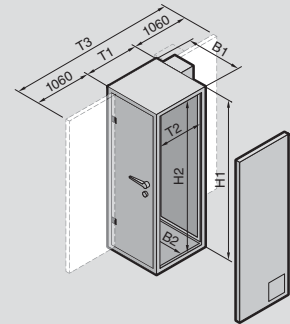

Technical information:
Available on the Internet.

U		42	47	42	47
External dimensions mm	Width (B1)	1100	1100	1100	1100
	Height (H1)	2210	2410	2210	2410
	Depth (T1)	1200	1200	1400	1400
Internal dimensions mm	Width (B2)	920	920	920	920
	Height (H2)	2030	2230	2030	2230
	Depth (T2)	1000	1000	1200	1200
Model no. (Safe is configured on a project-specific basis)		7999.009	7999.009	7999.009	7999.009
Empty weight excluding cooling unit and excluding rack approx. kg		660	700	730	800

Accessories					
TS IT rack with air baffle plates	W 600 x H 2000 x D 1000	7995.045	–	–	–
	W 600 x H 2200 x D 1000	–	7995.046	–	–
	W 800 x H 2000 x D 1000	7995.047	–	–	–
	W 800 x H 2200 x D 1000	–	7995.048	–	–
Fire alarm and extinguisher system DET-AC/EFD Plus		see page 66	see page 66	see page 66	see page 66
CMC monitoring system		see page 67	see page 67	see page 67	see page 67
PSM – Power System Module busbar		see page 68	see page 68	see page 68	see page 68
PDU – Power Distribution Unit		see page 68	see page 68	see page 68	see page 68
Split cooling solutions		from page 63	from page 63	from page 63	from page 63
LCP – Liquid Cooling Package, rack depth 1000 mm		see page 43	see page 43	see page 43	see page 43

Standard protection from:



Fire



Extinguishing water



Corrosive gases



Vandalism



Unauthorised access



Dust



Theft/burglary

Options for level E modular safe

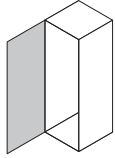
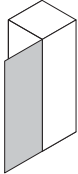
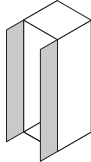
Operator door	L/h DIN door hinge	R/h DIN door hinge	Bifold door
			
	■	□	□

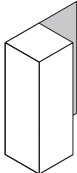
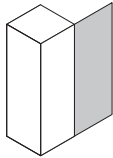
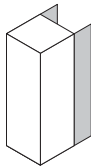

Service door	L/h DIN door hinge	R/h DIN door hinge	Bifold door
			
	■	□	□

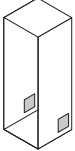
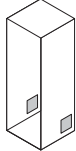
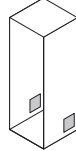
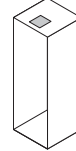
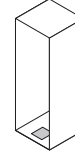
Cable entry	Soft duct ¹⁾ in both side elements	Hard duct ²⁾ in both side elements	Cable box ³⁾ in both side elements	Hard duct ²⁾ in top element	Hard duct ²⁾ in base element
					
	■	□	□	□	□



¹⁾ Size of soft duct: approx. 267 x 165 mm
For fire protection reasons, the duct may be configured up to a max. of 60% with cable up to a diameter of 15 mm and conduits up to a diameter of 18 mm.



²⁾ Size of hard duct: 2 panels each 120 x 120 mm

³⁾ Size of cable box: Cables up to a diameter of 15 mm and hoses up to a diameter of 44 mm may be routed through the cable box. No conduits may be routed through the cable box.

Locks	Key lock with 2 keys	Electronic combination lock ¹⁾	Electronic combination lock for activation via an access control system supplied by the customer
	■	□	□

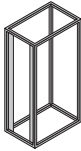

¹⁾ First code, second code and double code allocation possible. Key-based opening for inspection purposes supported.

TS IT rack with air baffle plates								
	600				800			
Width mm								
Height mm	2000	2200	2000	2200	2000	2200	2000	2200
Depth mm	1000	1000	1200	1200	1000	1000	1200	1200
Model No.	7995.045	7995.046	On request		7995.047	7995.048	On request	
	□	□	□	□	□	□	□	□

■ Included with the supply □ Optional

Supporting structure	Steel supporting structure to compensate for the raised floor height when siting the modular safe on the bare floor. The height of the supporting structure is selectable between 100 mm and 1000 mm.	Steel supporting structure to compensate for the raised floor height when siting the modular safe on the bare floor. The supporting structure has a fire-proof covering. The height of the supporting structure is selectable between 100 mm and 1000 mm.
	□	□

■ Included with the supply □ Optional



Level B modular safe



Applications:

- Basic protection against potential physical threats for IT components. Targeted configuration components transform the safe into a complete, compact data centre.

Benefits:

- Modular layout for installation in hard-to-access locations
- Lower weight than the Level E modular safe
- Tested security – testing has been carried out by accredited institutes and confirmed with test reports.

Protection standards:

- Fire protection – fire resistance class EI 90/F 90 to DIN EN 1363-1: 1999 based on DIN EN 4102-2: 1997
- Burglar resistance RC 2, tool attack analogous to DIN EN 1630/2011-09/RC 2
- Smoke protection based on DIN EN 18 1634-3: 2005-01
- Protection category IP 56 to IEC 60 529: 2000

Material:

- Sheet steel, coated

Colour:

- Enclosure and rear door: RAL 7035
- Operator door: RAL 9005

Supply includes:

- Security safe with integral TS 8 frame
- Front and rear 482.6 mm (19") level
- Adjusted air baffle plates
- Every side element is prepared for one cable entry at the bottom and one cable entry at the top
- Operator and service door with swing-lever handle and semi-cylinder

Optional:

- Choice of door hinges
- Bifold doors
- Different cable entry systems
- Cable entry additionally in the top and base element
- Different lock variants
- Supporting structure with fire protection

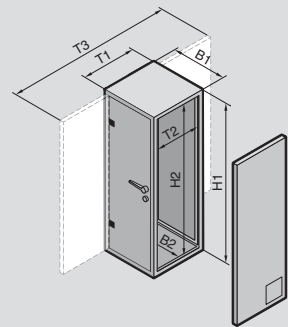

Technical information:
Available on the Internet.

U		42	47	42	47
External dimensions mm	Width (B1)	1115	1115	1115	1115
	Height (H1)	2205	2405	2205	2405
	Depth (T1)	1353	1353	1553	1553
	Depth (T3)	3274	3274	3474	3474
Internal dimensions mm	Width (B2)	900	900	900	900
	Height (H2)	2000	2200	2000	2200
	Depth (T2)	1060	1060	1260	1260
Model no. (Safe is configured on a project-specific basis)		7999.709	7999.709	7999.709	7999.709
Empty weight excluding cooling unit approx. kg		595	630	660	700
Accessories					
Fire alarm and extinguisher system DET-AC/EFD Plus		see page 66	see page 66	see page 66	see page 66
CMC monitoring system		see page 67	see page 67	see page 67	see page 67
PSM – Power System Module busbar		see page 68	see page 68	see page 68	see page 68
PDU – Power Distribution Unit		see page 68	see page 68	see page 68	see page 68
Split cooling solutions		from page 63	from page 63	from page 63	from page 63
LCP – Liquid Cooling Package, rack depth 1000 mm		see page 43	see page 43	see page 43	see page 43

Standard protection from:



Fire



Extinguishing water



Corrosive gases



Vandalism



Unauthorised access



Dust



Theft/burglary

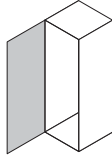
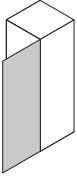
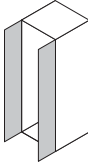

Options for level B modular safe

Operator door	L/h DIN door hinge	R/h DIN door hinge	Bifold door
			
	■	□	□

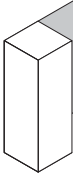
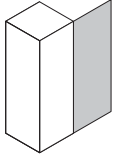
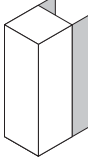

Service door	L/h DIN door hinge	R/h DIN door hinge	Bifold door
			
	■	□	□

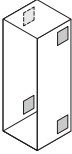

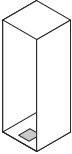
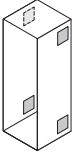
Cable entry	Soft duct ¹⁾ in both side elements	Cable box ²⁾ in top element	Cable box ²⁾ in base element	Cable box ²⁾ in both side elements
				
	■	□	□	□

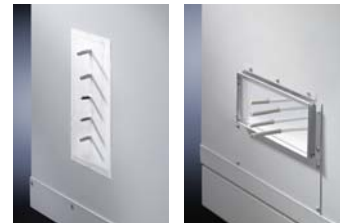

¹⁾ Size of soft duct: approx. 267 x 165 mm
For fire protection reasons, the duct may be configured up to a max. of 60% with cable up to a diameter of 15 mm and conduits up to a diameter of 18 mm.

²⁾ Size of cable box: Cables up to a diameter of 15 mm and hoses up to a diameter of 44 mm may be routed through the cable box. No conduits may be routed through the cable box.

Locks	Swing lever handle with interchangeable semi-cylinder	Swing lever handle with electronic lock for external activation	Swing lever handle with electronic lock with combination code
	■	□	□



Supporting structure	Steel supporting structure to compensate for the raised floor height when siting the modular safe on the bare floor. The supporting structure has a fire-proof covering. The height of the supporting structure is selectable between 100 mm and 1000 mm.		
	□	□	□

■ Included with the supply □ Optional

Level A compact safe



Applications:

- Protection for servers and storage applications
- Protection for business-critical data
- Storage of personal data, e.g. doctors' surgeries or tax advisors

Benefits:

- Complete system with built-in cooling and 482.6 mm (19") rack
- High level of operational and service-friendliness thanks to the two-door system
- Compatibility with other infrastructure elements

Protection standards:

- Fire resistance class F 90 to DIN 4102 Part 2, compliance with limits $\Delta T < 50$ K, rel. humidity $< 85\%$ over 10 minutes
- Burglar resistance WK II, tool attack analogous to DIN V ENV 1630/1999-04/WK II
- Protection category IP 55 to IEC 60 529

The tests were performed as system tests and confirmed with test reports.

Material:

- Sheet steel, coated

Colour:

- Enclosure and service door: RAL 7035
- Operator door: RAL 9005

Supply includes:

- Security enclosure with operating and service doors (three-point locking)
- Cable entry in both side elements
- Cooling 2.4 kW designed as a split unit

Technical information:

Available on the Internet.

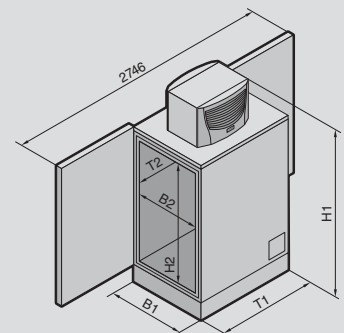

U		15
Cooling capacity kW		2.4
External dimensions mm	Width (B1) mm	806
	Height (H1) mm	1699
	Depth (T1) mm	1270
Internal dimensions mm	Width (B2) mm	620
	Height (H2) mm	827
	Depth (T2) mm	1024
Weight excluding internal fittings, including climate control unit approx. kg		360
Model No. Basic Safe with built-in 482.6 mm (19") rack		7999.999
Model No. Basic Safe without built-in 482.6 mm (19") rack		7999.898
Accessories		
482.6 mm (19") rack, 15 U, depth 1000 mm		7995.992
Fire alarm and extinguisher system DET-AC/EFD Plus		see page 66
CMC monitoring system		see page 67
PDU – Power Distribution Unit with busbar		see page 68

Standard protection from:



Fire



Extinguishing water



Vandalism



Unauthorised access



Dust



Theft/burglary

Compact split cooling solution for modular safes



■ The individual systems all have separate, hermetically sealed internal and external circuits. This means that dust and flue gases are unable to ingress the modular safe via the cooling system. The internal and external unit are connected to one another via coolant lines and control cables and shielded for fire protection.

■ Air routing inside the safe is horizontal. Modified air baffle plates ensure targeted air routing. By separating the "cold side" from the "hot side", air short-circuits are avoided, and the efficiency of cooling is enhanced. The compact split cooling solutions are suitable for use in rooms with climate control in the building or adequate ventilation, and low or no noise level requirements. The evaporator coil is fastened to the side panel on the inside of the modular safe, and the external device on the service door.

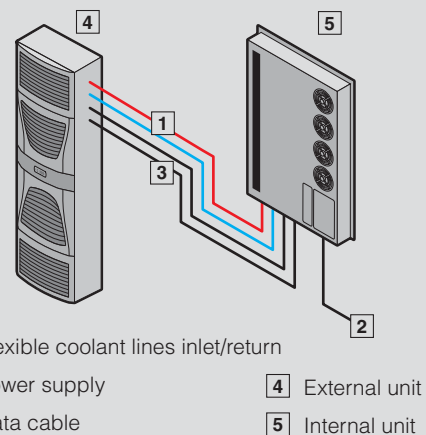

Model No.		3126.230	3126.240
Rated operating voltage V, Hz		400/460, 3~, 50/60	
Dimensions mm	W x H x D external unit	500 x 1580 x 231	
	W x H x D internal unit	804 x 1544 x 100	
Useful cooling output \dot{Q}_k to DIN 3168	L 35 L 35	2500 W/3090 W	4000 W/4010 W
	L 35 L 50	2070 W/2300 W	3020 W/3250 W
Rated current max.		3.3 A/3.5 A	4.1 A/4.8 A
Start-up current		14.2 A/14.7 A	15.2 A/15.8 A
Pre-fuse T		6.3 – 10.0 A	
Motor circuit-breaker		■	■
Power consumption P_{el} to DIN 3168	L 35 L 35	1275 W/1615 W	1620 W/2125 W
	L 35 L 50	1525 W/1920 W	1825 W/2835 W
Refrigeration factor $e = \dot{Q}_k/P_{el}$	L 35 L 35	2.0	2.5
Refrigerant		R134a, 1500 g	R134a, 2900 g
Permissible operating pressure p. max.		28 bar	25 bar
Temperature and setting range		+20 °C to +55 °C	
Noise level dB (A)		< 70	< 72
Protection category to IEC 60 529	Internal circuit	IP 54	IP 54
	External circuit	IP 24	IP 24
Weight	External unit	65 kg	65 kg
	Internal unit	70 kg	70 kg
Colour		RAL 7035	RAL 7035
Temperature control		Comfort controller (factory setting +25 °C)	

Split outdoor cooling solution for modular safes



■ When using the outdoor variant, the internal circuit of the cooling unit is secured to the side panel on the inside of the safe. The external unit is positioned outside of the building. The internal and external units are connected to one another via coolant lines and control cables. The hot air from the servers is drawn in at the rear of the safe, and the cooled air is expelled in front of the 482.6 mm (19") level. Benefits of the outdoor model: The waste heat is routed directly to the outside. As a result, room ventilation or air-conditioning is not necessary.

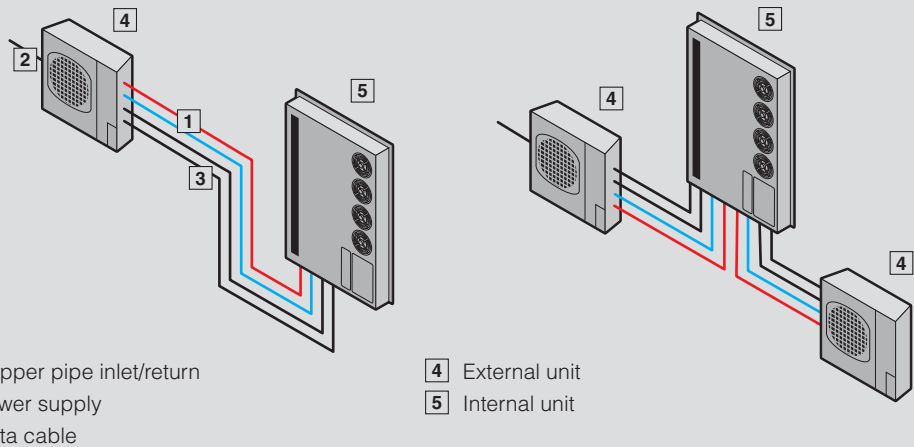

Model No.	7999.963	7999.965	7999.964	7999.966
Redundancy	–	–	■	■
Rated operating voltage V, Hz	230 V, 50 Hz, 1~	400 V, 50 Hz, 3~	230 V, 50 Hz, 1~ (2 x)	400 V, 50 Hz, 3~ (2 x)
Dimensions of external unit, mm	W x H x D	795 x 610 x 290	900 x 680 x 340 (2 x)	795 x 610 x 290
Useful cooling output \dot{Q}_k to DIN 3168	L 35 L 35	2400 W	5000 W	2400 W
Rated current max.	3.8 A	4.1 A	3.8 A	4.1 A
Start-up current per unit	19.5 A	35 A	19.5 A	35 A
Pre-fuse T	16 A	3 x 16 A	16 A (2 x)	3 x 16 A (2 x)
Refrigerant	R410 a			
Temperature and setting range	–15 °C to +35 °C			
Weight	External unit	38 kg	74 kg	2 x 38 kg
	Internal unit	59 kg	59 kg	63 kg
Colour	RAL 7035			
Accessories				
Coolant line incl. electric control cable for 2400 W, length 20 m	7999.961	–	7999.961	–
Coolant line incl. electric control cable for 5000 W, length 20 m	–	7999.962	–	7999.962

Split outdoor cooling solution with inverter technology



■ The cooling unit with inverter technology allows targeted speed control of the compressor. The coolant volume is regulated via the electronic expansion valve. Adaptation to cooling requirements facilitates energy savings of up to 40%. The cold air is expelled in front of the 482.6 mm (19") level by the internal unit (evaporator coil), while the hot air is drawn in at the rear.

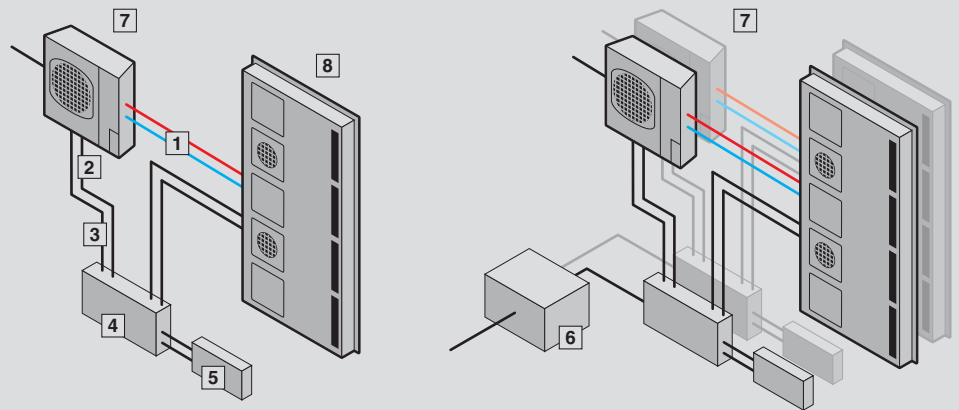

- 1 Copper pipe inlet/return
- 2 Power supply
- 3 Data cable
- 4 Control box
- 5 Operating unit
- 6 Switch box
- 7 External unit
- 8 Internal unit

Model No.	7999.991	7999.992
Redundancy	–	■
Rated operating voltage V, Hz	230 V, 50 Hz, 1~	230 V, 50 Hz, 1~ (2 x)
Dimensions of external unit, mm	W x H x D 900 x 795 x 320	900 x 795 x 320 (2 x)
Useful cooling output \dot{Q}_k to DIN 3168	L 18¹⁾/L 35 L 18/L 43	7850 W 7030 W
Rated current max.	13.9 A	13.9 A
Start-up current	36 A	36 A
Pre-fuse T	25 A	25 A (2 x)
Refrigerant	R 410a	R 410a
Temperature and setting range	–15 °C to +43 °C	–15 °C to +43 °C
Noise level	48 – 49 dB (A)	48 – 49 dB (A)
Weight	External unit	63 kg
	Internal unit	70 kg
Colour	RAL 7035	
Also required		
Heat exchanger (evaporator coil)	3126.270	3126.270²⁾

¹⁾ Server inlet temperature

²⁾ 2 heat exchangers are required.

Fire alarm and extinguisher system DET-AC/EFD Plus



Benefits:

- Early fire detection
- Automatic extinguishing
 - Innovative extinguisher gas NOVEC 1230
 - Eco-friendly
 - Uncritical for IT components
- 482.6 mm (19") rack mount with just 1 U

DET-AC Plus

Compact fire alarm and active extinguisher system with smoke extraction system, built into one height unit. The detection system is identical to that used in the EFD Plus system. Fire extinguishing with the extinguisher gas NOVEC 1230 is automatically activated when a main alarm is triggered. With the extinguisher gas supply provided, a volume of up to 3 m³ can be extinguished. The collective fault signal and the alarms may be forwarded to the CMC.

DET-AC Plus slave

In conjunction with the DET-AC Plus slave system, up to five bayed enclosures may be extinguished. In addition to the DET-AC Plus unit, a DET-AC Plus slave unit is used for each additional enclosure and contains the extinguisher gas for one enclosure. The pipework from the DET-AC Plus system is laid in all enclosures to facilitate detection.

EFD Plus

Compact early fire detection system with active smoke extraction system. The integral fan continuously extracts the air from the enclosure, and passes it over two smoke detectors. The first smoke detector is extremely sensitive and triggers a pre-alarm. The second smoke detector triggers the main alarm.

	Fire alarm and extinguisher system DET-AC Plus	Add-on unit DET-AC Plus slave	Early fire detection system EFD Plus
Width (B) mm	482.6 (19" rack mount)	482.6 (19" rack mount)	482.6 (19" rack mount)
Height (H) mm	44 (1 U)	44 (1 U)	44 (1 U)
Depth (T) mm	640	570	500
Weight kg	approx. 15	approx. 12	approx. 8
Model No.	7338.120	7338.320	7338.220

Protection category	IP 20	IP 20	IP 20
Ambient temperature (operation)	+10 °C to +35 °C	+10 °C to +35 °C	+10 °C to +35 °C
Battery storage	-10 °C to +50 °C	-10 °C to +50 °C	-10 °C to +50 °C
Operating voltage	100/240 V AC 50/60 Hz	24 V DC	100/240 V AC 50/60 Hz
Uninterruptible mains electricity operation	2 x 12 V; 2.2 A/approx. 4 h	2 x 12 V; 2.2 A/approx. 4 h	2 x 12 V; 2.2 A/approx. 4 h
Connections	3 RJ 12 connectors for connecting to the CMC, alternatively 3 relay outputs, max. contact load 24 V DC/0.5 A		
Sensors	2 different scattered-light sensors	–	2 different scattered-light sensors
Display	LCD display with plain text information	–	LCD display with plain text information
No. of slave modules	max. 4	–	max. 5
No. of monitored enclosures	max. 5	–	max. 5
Extinguisher gas	NOVEC 1230	NOVEC 1230	–
Fill volume of extinguisher gas	3.2 kg	3.2 kg	–
Admissible max. protection volume	3 m ³	3 m ³	–

Also required

	7338.130	7338.130	7338.130	Cat. 33, page
Pipe kit	7338.130	7338.130	7338.130	
RJ 12 cable for alarm relaying to CMC, packs of 2	7320.814 ¹⁾	7320.814 ¹⁾	7320.814 ¹⁾	775
Access sensors	7320.530	7320.530	–	773
Depth-variable slide rails	–	–	5501.480	749

¹⁾ 2 packs are required.

CMC III monitoring system

CMC III monitoring system

The CMC III monitoring system controls physical parameters such as the temperature inside the modular safe.

The user defines limits for the various parameters. These are fully automatically monitored by the CMC. If the limits are exceeded or undercut, the CMC emits an alarm which may optionally be notified via e-mail or SMS.

The system may also be connected to the customer network (via OPC/SNMP) to represent messages or values directly in the control room system (SCADA/BMS/NMS).

The CMC III system is plug & play-ready, sensors are detected automatically, and the Web user interface is easy to use even with no prior knowledge.

The CMC Compact basic unit is available for small monitoring units, and supports the connection of up to four sensors. The CMC III Processing Unit for larger monitoring units supports the connection of up to 32 sensors.

There is a 24 V DC power supply with a redundant design, but power can also be supplied via the integral Power over Ethernet (PoE).

In addition to temperature monitoring, both the alarms and collective fault signal from the fire alarm and extinguishing system, as well as the fault signalling from the climate control system, may be switched to the CMC.

	Packs of	Model No.
CMC III Processing Unit Compact	1	7030.010
Power pack 100 – 240 V AC to 24 V DC	1	7030.060
Mounting unit, 1 U	1	7030.070
USB programming cable	1	7030.080
CAN-bus cable 0.5 m	5	7030.090
CAN-bus cable 1.0 m	1	7030.091
CAN-bus unit for CMC-TC sensors	3	7030.100
Temperature sensor	1	7030.110
Connection cable	1	7200.210

Note:

For more CMC III sensors, see Catalogue 33, page 773.



Application example for monitoring a modular safe with fire alarm and extinguisher system

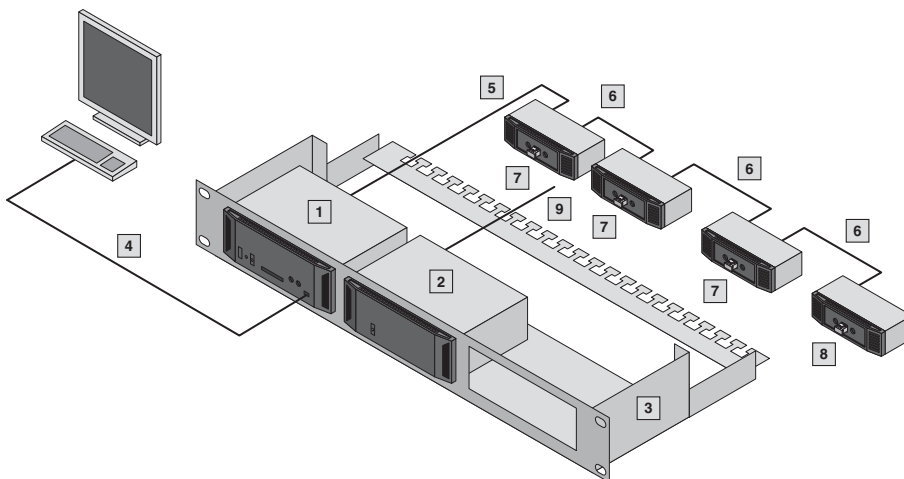

- 1 CMC III Processing Unit Compact (with front infrared access sensor, temperature sensor, 2/1 inputs/outputs)
- 2 Power pack 100 – 240 V AC to 24 V DC
- 3 Mounting unit, 1 U
- 4 Programming cable USB
- 5 CAN-bus connection cable 1 m
- 6 CAN-bus connection cable 0.5 m
- 7 CAN-bus sensor
- 8 Temperature sensor
- 9 Connection cable

Power distribution/supply



PDU Power Distribution Unit

Compact power distribution for modular safe applications

The compact PDU allows any modular safe to be quickly and easily equipped with a professional power distribution system. With this latest generation of modular safes, installation is tool-free and takes just seconds. The required mounting kits and assembly parts are included with the supply. What is more, the required connection cable with integral CEE connectors is already pre-fitted, so that the PDU is ready to use immediately.

Single-phase and 3-phase PDU versions are available with input currents ranging from 16 A to 63 A, so that the correct power distribution is available to suit every rack and its specific energy requirements.

PDU versions – Differences

There are four main PDU variants:

- PDU basic: Robust, compact basic power distributor for the IT environment
- PDU metered:
 - Basic version supplemented by energy measurement per phase and/or infeed
 - Rapid overview of the power requirements of a complete modular safe
- PDU switched: Measurement function per phase/input and individually switchable output slots
- PDU managed:
 - High-end IT rack power distribution
 - Energy measurement function for each individual output and individually switchable outputs. This version supports comprehensive monitoring of each individual output slot, to allow early detection of changes to the current rating or malfunctions in power packs
 - Detailed consumption analyses down to server level, to help reduce energy consumption

PDU international (selection)

PDU version ¹⁾	Power		Qty./pin patterns			Dimensions		
	No. of phases	Phase current	Input	Outputs C13	Outputs C19	PDU length (mm)	Recommended for Modular Safe	Model No.
Basic	1	16 A	CEE	24	4	970	Level B/E	7955.110
		32 A	CEE	24	4	1110	Level B/E	7955.111
	3	16 A	CEE	24	6	1140	Level B/E	7955.132
		32 A	CEE	24	6	1360	Level B/E	7955.133
Metered	1	16 A	C20	12	None	580	Basic Safe	7955.201
		16 A	CEE	24	4	1220	Level B/E	7955.210
		32 A	CEE	24	4	1360	Level B/E	7955.211
	3	16 A	CEE	24	6	1390	Level B/E	7955.232
		32 A	CEE	24	6	1610	Level B/E	7955.233
		16 A	C20	12	None	580	Basic Safe	7955.301
Switched	1	16 A	CEE	24	4	1220	Level B/E	7955.310
		32 A	CEE	24	4	1360	Level B/E	7955.311
		16 A	CEE	24	6	1390	Level B/E	7955.332
	3	32 A	CEE	24	6	1610	Level B/E	7955.333
Managed	1	16 A	C20	12	None	580	Basic Safe	7955.401
		16 A	CEE	24	4	1220	Level B/E	7955.410
		32 A	CEE	24	4	1360	Level B/E	7955.411
	3	16 A	CEE	24	6	1390	Level B/E	7955.432
		32 A	CEE	24	6	1610	Level B/E	7955.433
		16 A	C20	12	None	580	Basic Safe	7955.401

¹⁾ For more variants and technical details, see Innovations 2012, from page 91



PSM – Modular power distribution for modular safe applications

The PSM system offers an optimum IT power distribution system, whose configuration (type and quantity of output slots) may be modified in line with altered requirements at any time, even whilst operational. To this end, a range of plug-in modules (e.g. earthing-pin, EC 60 320, C13/C19, UK plug etc.) is available.

Plug-in modules with the option of switchable individual outputs and PSM blade bars with integral current and output measurement are also available. Data communication and network connection occur via the CMC III. Together with the CMC III and in conjunction with other CMC III sensors e.g. for ambient parameters such as temperature and humidity, this allows you to create a comprehensive monitoring solution for your modular safe.

Note:

See Cat. 33, from page 383.

Power distribution/supply



UPS system PMC 12

The PMC 12 UPS is distinguished by its use of double-conversion technology. Double-conversion technology to the highest classification VFI-SS-111 provides the basis for an optimum supply voltage to all connected loads. This makes the UPS ideally suited for all applications in the IT environment and for other requirements such as automation technology, system control etc. A scalable autonomy of up to 29 minutes at 100% load produces a broad application spectrum.

- With 90° swivellable LCD
- Serial interface and Emergency Power Off (EPO) contact
- Optional SNMP monitoring card
- Batteries "hot swap" compatible, may be exchanged from the front
- External batteries with 4.5 kVA and 6 kVA

PMC 12 UPS system

Model No. PMC 12 UPS control unit		7857.433	7857.434
Model No. battery pack (at least 1 x is required)		7857.442	7857.442
Electrical specifications			
Power	VA	4500	6000
Active power	W	3500	4800
Heat loss	W	315	420
Operating voltage	V	230	230
Frequency	Hz	50	50
Rated current (max. output)	A	20	26
Power factor	PF	0.8	0.8
Efficiency (AC mode)	%	90	90
Battery life (at 20 °C/EUROBAT)		5 years	
Electrical connection (input and output together)		Harting Han-Q4/2	
Mechanical specifications			
Dimensions of UPS		UPS	Battery pack
Width	mm	450 (482.6 mm/19")	450 (482.6 mm/19")
Height	mm	88 (2 U)	135 (3 U)
Depth	mm	680	650
Weight	kg	24	55
Protection category	IP	20	20
Operating temperature	°C	10 to 35	10 to 30/20 recommended
Communication interfaces			
Integral interface		RS232 (serial)	
Emergency Power Off (EPO)		Connector (2-pin)	
SNMP-UPS monitoring card (network card)		7857.420	
UPS relay card (alarm messages to GLT)		7857.410	
Standards and certifications			
Power		EN 62 040-3	
EMC		EN 62 040-2 EN 61 000-4-2 EN 61 000-3-2 EN 50 091-2	
Labelling		CE, FCC	
UPS autonomies/stored energy times		4.5 kVA (100% load)	6 kVA (100% load)
Number of battery packs	1	9 minutes	8 minutes
	2	23 minutes	20 minutes
	3	39 minutes	33 minutes

Battery ventilation system for installation in Level E, Level B modular safes

The battery pack of the UPS system contains sealed lead gel batteries. According to EN standard 50 272-2, battery systems must be ventilated. Given the high density of the modular safe, battery packs must not be installed in the safes without a ventilation solution.

Rittal offers a suitable ventilation system for the aforementioned battery pack of PMC 12, 4.5 and 6 kVA, for installation in the modular safes. The enclosure has a ventilation system which retains the protection standards of the modular safe. Vented battery enclosure system for one or two battery packs 4 U/8 U available on request.

Rittal – The System.

Faster – better – worldwide.



ENCLOSURES

POWER DISTRIBUTION

CLIMATE CONTROL

FRIEDHELM LOH GROUP

The IT security room system.

With Rittal IT security rooms, we offer a targeted spectrum of products for the physical protection of your IT. From server rooms to large data centres, from basic protection to the fulfilment of international high-MTBF standards. System-tested products are tested as a complete structure, taking into account the interactions between all components. During testing, allowance is made for built-in modules such as doors, cable bushing systems and ventilation units. Benefit from multifunctional risk coverage (fire, water, burglary) and compliance with the latest EN and DIN standards. Rittal also offers complete turnkey solutions for climate control, power back-up, monitoring, fire detection and extinguishing, all from a single source.

Contents

The IT security room system.	Page 72
Targeted physical protection for your IT.....	Page 74
IT security rooms LER Basic/LER Extend	Page 76
IT security rooms LSR 18.6 E	Page 77
Better.	Page 78
System-tested accessories	Page 80
Engineering, service & support	Page 81
Security rooms and IT infrastructures	Page 82

Rittal – The System.

Faster – better – worldwide.

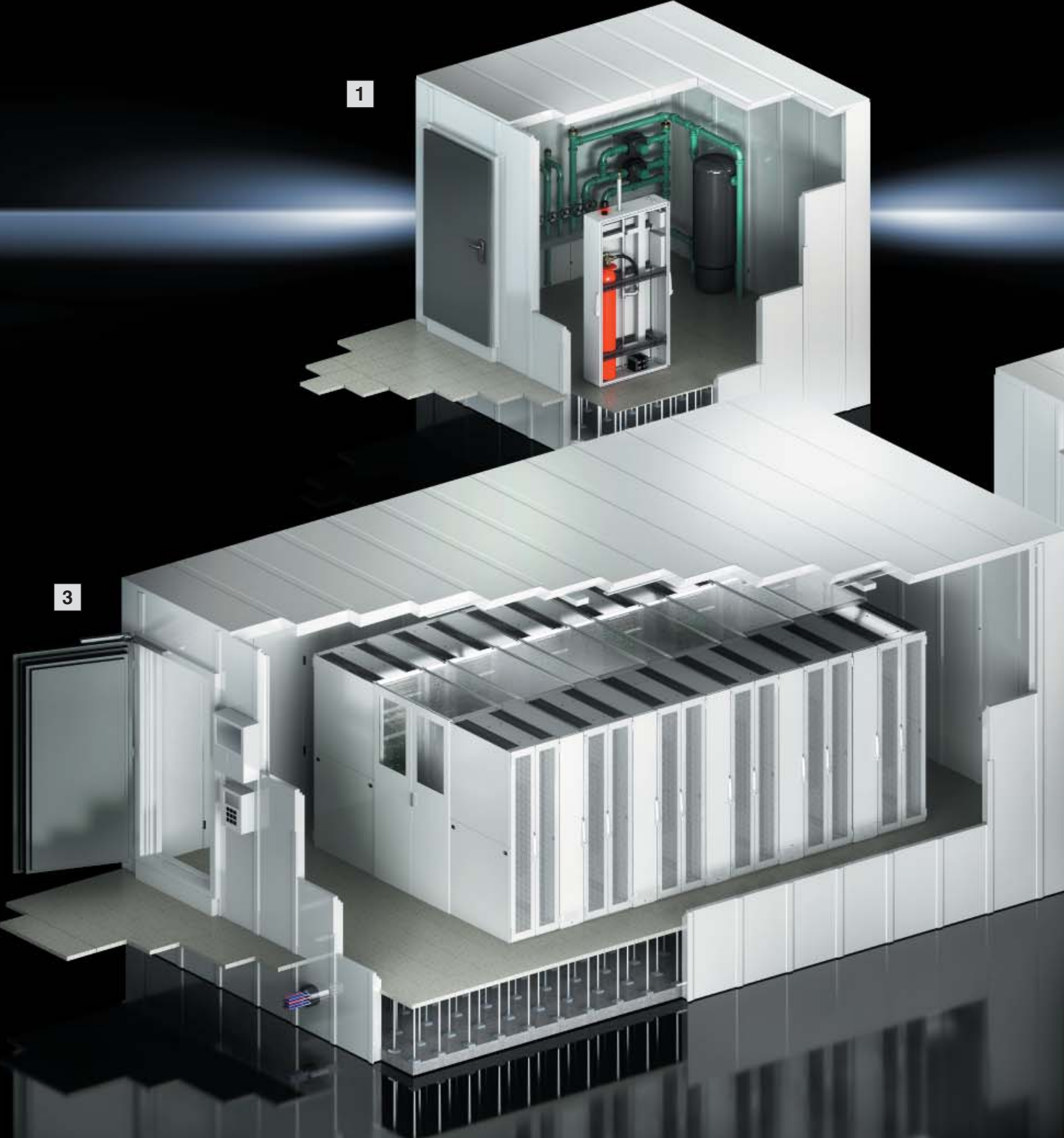

ENCLOSURES

POWER DISTRIBUTION

CLIMATE CONTROL

FRIEDHELM LOH GROUP

The IT security room system.

- Trusted partner with decades of experience
- Conceptual design and consulting from one of the world's leading companies
- Multifunctional protection from physical threats
- Scalable, system-tested security
- Independent quality monitoring to international standards
- Modular room-within-a-room solution for targeted expansion, the option of system dismantling and reassembly, and hence a high level of investment security

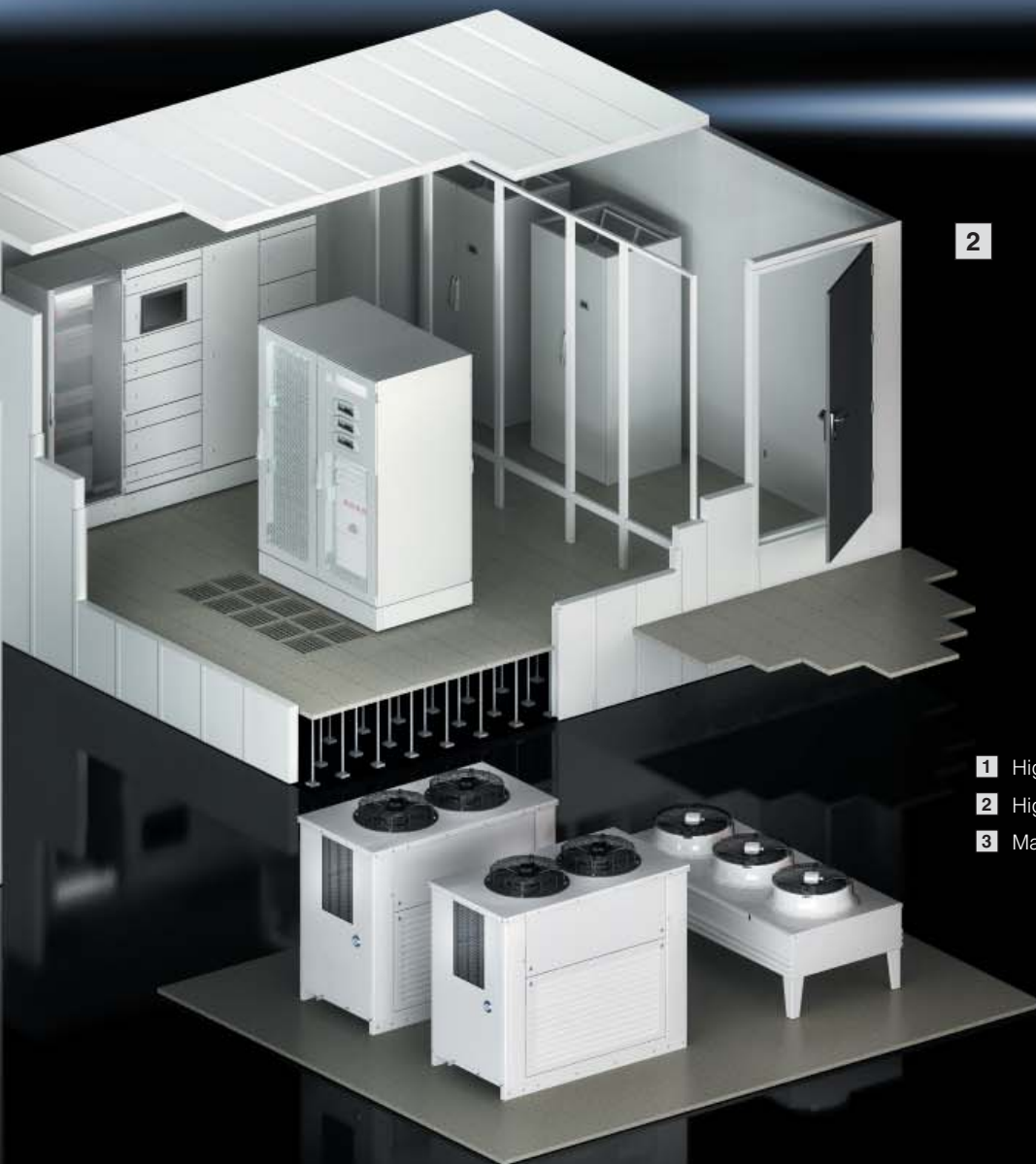

2

- 1 High security – LER Basic
- 2 High security – LER Extend
- 3 Maximum security – LSR 18.6 E



IT INFRASTRUCTURE

SOFTWARE & SERVICES



Targeted physical protection for your IT



Criterion	Standards
System testing	 Testing of the following quality ratings as complete system or structure
Fire protection	 ECB-S certification to EN 1047-2, 50 K temperature increase and 85% rel. humidity up to 24 hours (reheat period), 60 minutes flame impingement time
	50 K temperature increase and 85% rel. humidity without reheat period, 30 minutes flame impingement time
	F 120 to DIN 4102 F 90 to DIN 4102
Corrosive fire gases	Acrid gas-tightness based on DIN 18 095
Falling debris	Shock test of 200 kg
Water	IP x6 to IEC 60 529
Dust	IP 5x to IEC 60 529
Unauthorised access	WK IV to DIN V ENV 1630, door system only
	WK III to DIN V ENV 1630, or DIN V 18 103 (ET2)
	WK II to DIN V ENV 1630
Explosion	Detonation test
EMC	Protection against high-frequency irradiation and radiation

System-tested facilities are tested as a complete construction. This comprises the cellular structure and installation modules such as doors, cable bushing or ventilation units. By contrast, generic component testing only refers to individual parts.

Conventional constructions refer to room structures of plasterboard, concrete and other standard construction materials which do not offer sufficient protection for data centre applications. Conventional constructions are generally unsuitable for use as fire walls, and are therefore only type-tested.

Targeted physical protection for your IT

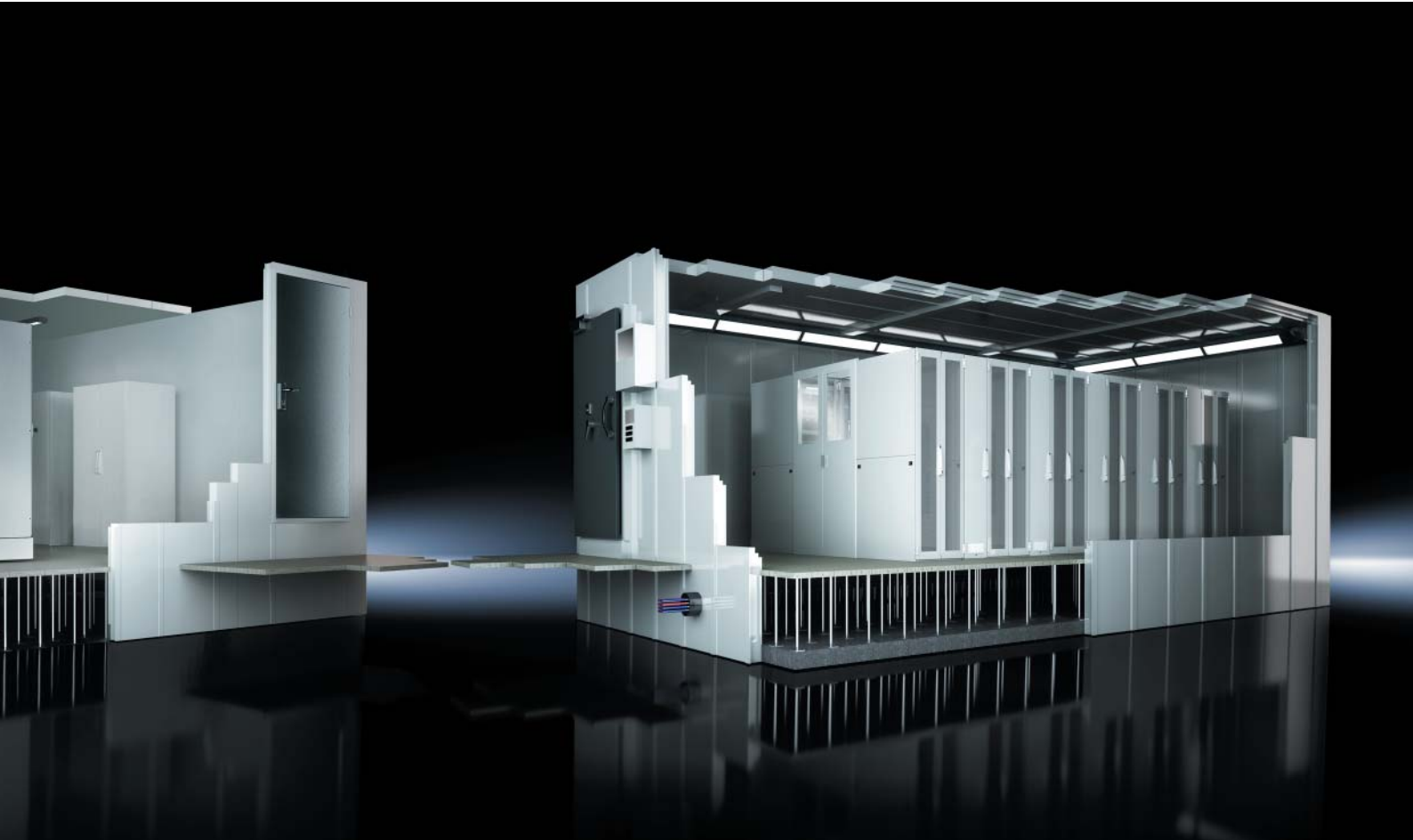

	High security LER Basic	High security LER Extend	Maximum security LSR 18.6 E
	■	■	■
	-	-	■
	-	■	-
	-	-	■
	■	■	-
	■	■	■
	■	■	■
	■	■	■
	■	■	■
	-	-	■
	-	■	■
	■	■	-
	-	-	■
	■	■	■

IT security rooms LER Basic/LER Extend

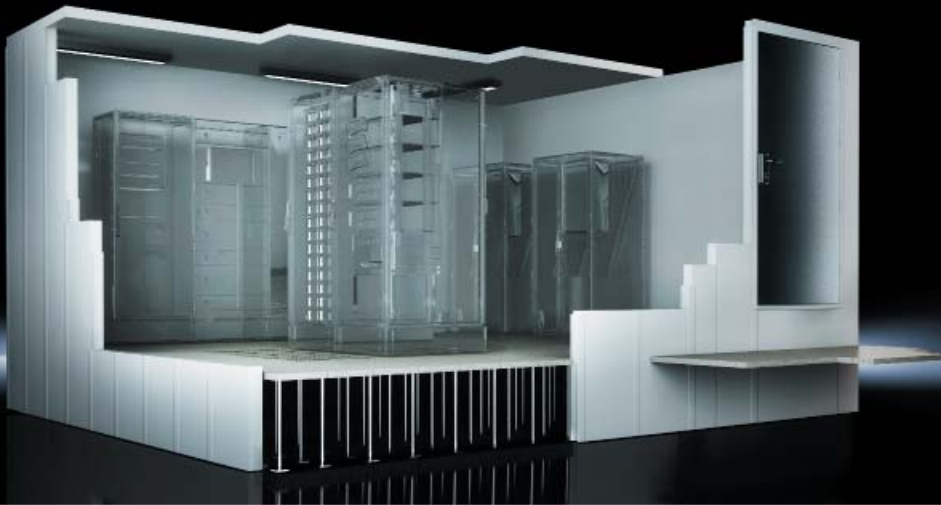

High security

The security rooms LER Basic and LER Extend offer high-quality, system-tested solutions. As basic and extended solutions, LER Basic and LER Extend are optimum security rooms for the protection of infrastructure components such as extinguisher systems, uninterrupted power supply and climate control.

Your benefits

- System-tested protection
- Multi-functional risk coverage
- Dust- and noise-reduced installation
- Dismantling and reassembly plus expansion = investment security
- Can be adapted for use with other room systems, e.g. LSR 18.6 E

LER Basic protection

- Fire resistance F 90 to DIN 4102, system-tested
- Fire resistance F 120 to DIN 4102, type-tested
- Dust- and watertight to IP 56 to EN 60 529
- Protection against external access – resistance class II to DIN V ENV 1630
- EMC basic protection
- Acrid gas-tightness based on DIN 18 095
- Shock test with 3,000 Nm energy after 30 minutes flame impingement over standard temperature curve

LER Extend protection

- Extended protection for data centres based on the LER Basic
- Fire resistance according to the limits of EN 1047-2, max. 50 K temperature increase and 85% rel. humidity, 30 minutes flame impingement time
- Optionally resistance class III to EN 1630

LER room system construction

- Element core made of thermally effective insulation substance
- Robust, encapsulated sheet steel cassette panels
- Innovative connection technology using patented profile technology
- Use of temperature- and humidity-resistant seals
- Use of fire protection valves and sliding climate control doors (Extend)
- Dismantling and reassembly is possible at any time

Standard protection from:



Fire



Extinguishing water



Corrosive gases



Vandalism



Unauthorised access



Electromagnetic interference



Dust



Falling debris



Theft/burglary



Maximum security

The security room LSR 18.6 E offers maximum physical protection for data centres and IT system locations. The system was certified by ESSA (European Security Systems Association) to ECB-S regulations.

This certification confirms that the LSR 18.6 E meets the requirements of EN 1047-2 without restriction. Moreover, construction of the security room is subject to constant, independent quality monitoring.

Your benefits

- System-tested high-MTBF protection
- Multi-functional risk coverage
- Dust- and noise-reduced installation
- Dismantling and reassembly plus expansion = investment security
- ECB-S certification
- Independent quality monitoring
- Can be adapted for use with other room systems, e.g. LER Basic/Extend

LSR 18.6 E protection

- Fire resistance to quality class R60D to EN 1047-2 (fire resistance testing, shock testing, floor testing), system-tested
- Fire resistance EI 120/F 120 to EN 1363/DIN 4102, type-tested
- Protection against external access – resistance class WK III to EN 1630 system-tested for cellular structure and its built-in modules
- Extended protection against external access WK IV to EN 1630 for high-security door
- Protection against standing water, 72 h, 40 cm, maximum 20 drops
- Explosion testing subject to detonation test of 200 kg TNT from 40 m
- Protection against falling debris
- Dust- and water-tight to IP 56, category 1 (underpressure) to IEC 60 529
- EMC basic protection
- Optionally extendible EMC shielding to BSI TL-03304, including a shield attenuation measurement to IEEE standard 299
- Acrid gas-tightness based on DIN 18 095

LSR 18.6 E construction

- Complex 4-layer element core made of thermally effective insulation substances
- Robust, encapsulated sheet steel cassette panels
- High-security door, ECB-S tested, multiple lock, with panic release
- Patented connection system
- Fireproof floor elements
- Use of extremely temperature- and humidity-resistant seals
- Use of climate control dampers and cable bushing systems
- Dismantling or reassembly is possible at any time

Standard protection from:



Fire



Extinguishing water



Corrosive gases



Vandalism



Unauthorised access



Electromagnetic interference



Dust



Explosion



Falling debris



Theft/burglary



Mechanical access

Rittal – The System.

Faster – better – worldwide.



ENCLOSURES

POWER DISTRIBUTION

CLIMATE CONTROL

FRIEDHELM LOH GROUP

Better.

Protection for your IT systems

Are you aware of the weak points in your IT systems? Are you aware of the dangers they are exposed to? It is vitally important for your company to have all data permanently available, and to be able to process it at all times.

Rittal offers cost-effectively expandable designs and structures, with ecologically and economically optimised data centres offering a host of other benefits.

Your benefits

- Protection ranging from basic protection to high-MTBF
- Simple, flexible integration into existing building structures
- Expandability and lasting cost-effectiveness
- Optimum space utilisation, thanks to the flexible modular system
- Flexibility, by enclosing existing IT and infrastructure solutions
- System-tested protection from potential physical threats
- Room-within-a-room concept with the associated depreciation benefits
- Compatibility with cross-facility IT infrastructures
- High level of pre-manufacturing – fast assembly times
- May be constructed and extended with the IT systems operational

An ECB-S certified solution offers more than a type-tested solution

As one of the leading suppliers of security rooms, Rittal has received ECB certification for its security room LSR 18.6 E.

With this certification, the European Certification Body GmbH (ECB) confirms that the Rittal IT security room fully complies with the criteria set by the European standard EN 1047-2.

The prerequisite for ECB-S certification is a system-tested room. This includes testing the walls, the ceiling and the floor, as well as the door and the cable bushing, as a system-tested room with all transitions. During a fire resistance inspection, criteria such as temperature increase and relative humidity are evaluated. The room is also subject to a shock test, which simulates falling components.

Rittal is a professional supplier, backed up by many years of expertise. The ECB-S certified solutions have been in place since 2003, and are constantly being adapted to the optimised requirements of EN 1047-2.

Benefits of ECB-S certification

- System-tested room
- Optimum quality protection thanks to independent quality monitoring
- Improvement in the rating situation for loan applications and residual risk insurance
- Transparency for banks and insurance companies
- Compliance with European standards on IT protection

IT INFRASTRUCTURE

SOFTWARE & SERVICES



System-tested accessories

For IT security rooms



Door and access systems

Rittal IT security rooms are equipped with security door systems. These vary depending on the room system, ranging from the LER Basic, to the LER Extend through to the LSR 18.6 E. In order to provide the highest level of security, the security door system displays the following features.

The security door system features a highly fire-resistant, multi-walled steel door panel with surrounding door frame and all-round fire and seal fold. The door rebate area includes hollow-body rubber gaskets and expanding high-temperature seals, among other features. The lock system, which is equipped with a high-security bolt mechanism, locking bolts and panic release, is an essential component. The high-security bolt mechanism has a lock housing seat. Anyone still in the room in the event of an alarm (while the door is closed) can leave at any time by using the standardised panic release.

Door closing delay

An automatic door closing delay time in the event of an alarm can be adjusted.

Door monitoring systems

The floating contacts of the door monitoring systems are provided in a VdS interface distributor.

Door signal contact

There is a door signal contact for displaying the door opening status remotely, e.g. for routing a signal to a security control centre.

Bolt mechanism monitoring

There is a latch monitoring option for monitoring the bolt mechanism's lock bolts, e.g. for routing a signal to a burglar alarm system or security control centre.



Cable bushing systems

For larger quantities of cables or plug-in cable harnesses with large cross sections (e.g. bulk storage systems/peripherals).

For routing:

- mains supply cables
- signal and control lines of door and damper systems
- data and control lines of the customer's infrastructure

Variants:

- Hard duct systems DN 200 or KS-B
There is an enhanced level of protection against tampering in the vicinity of the cable entry.
- Round duct DN 200
Filled with sealing modules. For on-site cables, pipes and cable routes.
Also for retrofitting data and power supply cables.
- Hard duct KS-B open at the bottom
For installing a security room on top of the customer's existing data and power supply cables. Closed with sealing modules.
- Soft duct
Basic configuration. Filled with flexible sealing material. Also for retrofitting data and power supply cables.

Note

- It is recommended that closing of the duct systems is carried out by authorised Rittal professionals.
- Other hard and soft duct systems are optional, depending on the requirements profile and the security room equipment.

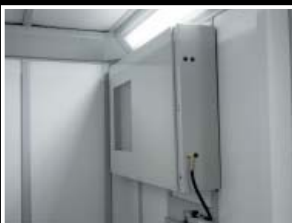

Climate and overpressure control dampers

For the closure of openings for fire prevention. Made from highly fire-resistant materials. Closure of the damper is current-independent.

Climate control dampers

With electromagnetic drive.

Overpressure control dampers

With electropneumatic drive. In the event of an alarm, the pressure is discharged by briefly opening the damper. Integration into the fresh air supply is also possible.



Fire protection valves

For the closure of openings in the security room for fire prevention. With highly effective seals for optimal closing of the valve.

- With electrical drive system (ventilation):
for closing ventilation and air-conditioning openings.
- With pneumatic drive system:
for overpressure discharge and for flue gas disposal.



Engineering, service & support

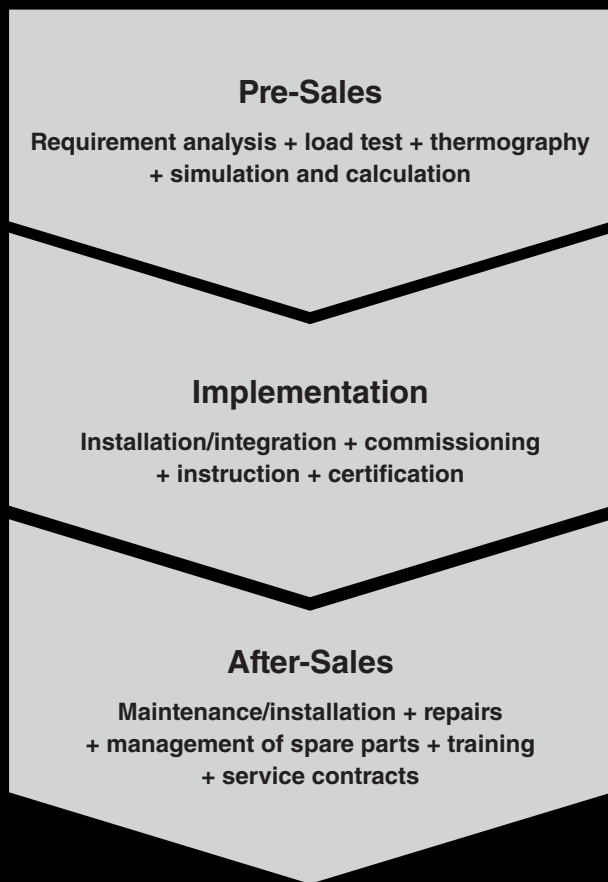

Rittal International Services

- Installations are carried out by internationally trained staff (Haiger training centre, SuperVisor system)
- Experienced staff with many years of expertise are constantly travelling all over the world
- Quality management (independent testing by outside experts, as well as internal quality testing covering laboratory and production inspections through to cross-facility system acceptance)
- Proven expertise in all areas (research and development, purchasing, sales, project planning, project management, servicing)



ENCLOSURES

POWER DISTRIBUTION

CLIMATE CONTROL

IT INFRASTRUCTURE

SOFTWARE & SERVICES

FRIEDHELM LOH GROUP

Make IT easy

Rittal – The System.

Faster – better – worldwide.

Security rooms and IT infrastructures

A perfect IT environment provides the basis for perfect business. Rittal designs, builds and optimises data centres on your behalf, thereby making an effective and efficient contribution to your corporate success. We will advise you, agree the details with you, and develop solutions that fit, down to the smallest detail.

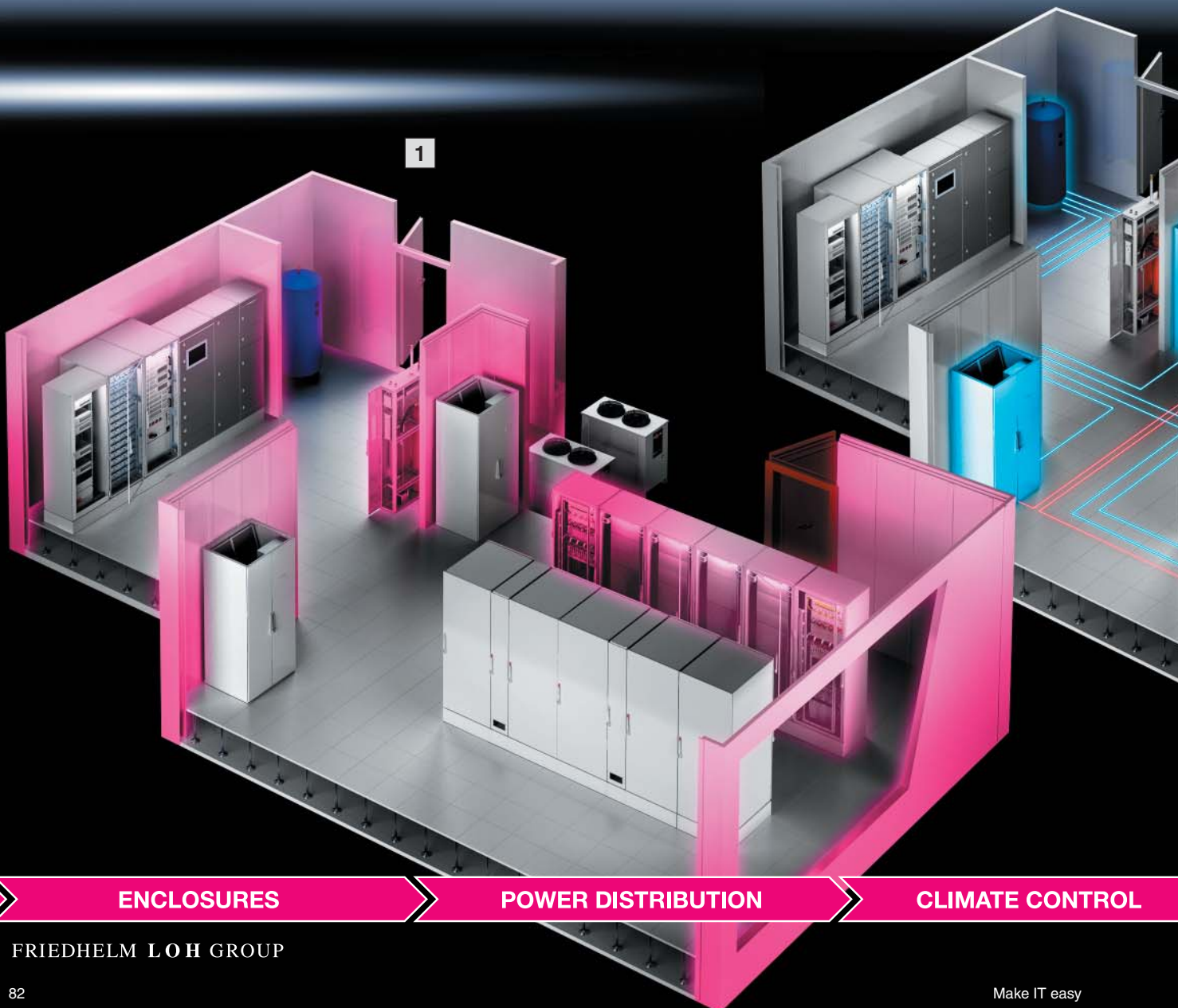

ENCLOSURES

POWER DISTRIBUTION

CLIMATE CONTROL

FRIEDHELM LOH GROUP

The benefits to you:

- You benefit from the integrated options offered by a full-range supplier.
- From the initial draft, through to the implementation phase and commissioning, you only deal with one point of contact.
- Your data centre project is clearly structured for your convenience.
- All participants and components are precisely coordinated and attuned with the project goals.
- Every detail contributes to the high overall performance capability of the system.



Rittal endorses the European Code of Conduct and strives consistently to achieve its goals.

1 Data centre construction

- Cross-facility engineering for implementing complete data centres (modularity, scalability, availability)
- Project and process management of the entire workflow
- Handling of all licensing procedures (construction applications, statics and other approvals)
- Preparation of various certifications, including the relevant international certificates (safety, energy efficiency, availability)

1 2 3 RiMatrix IT infrastructures

- Standardised server racks and network enclosures
- Scalable IT cooling concepts
- Modular power distribution and back-up
- High-MTBF IT security rooms, including certificates
- Complete system accessories for IT environments and data centres
- Software-based IT and infrastructure management system

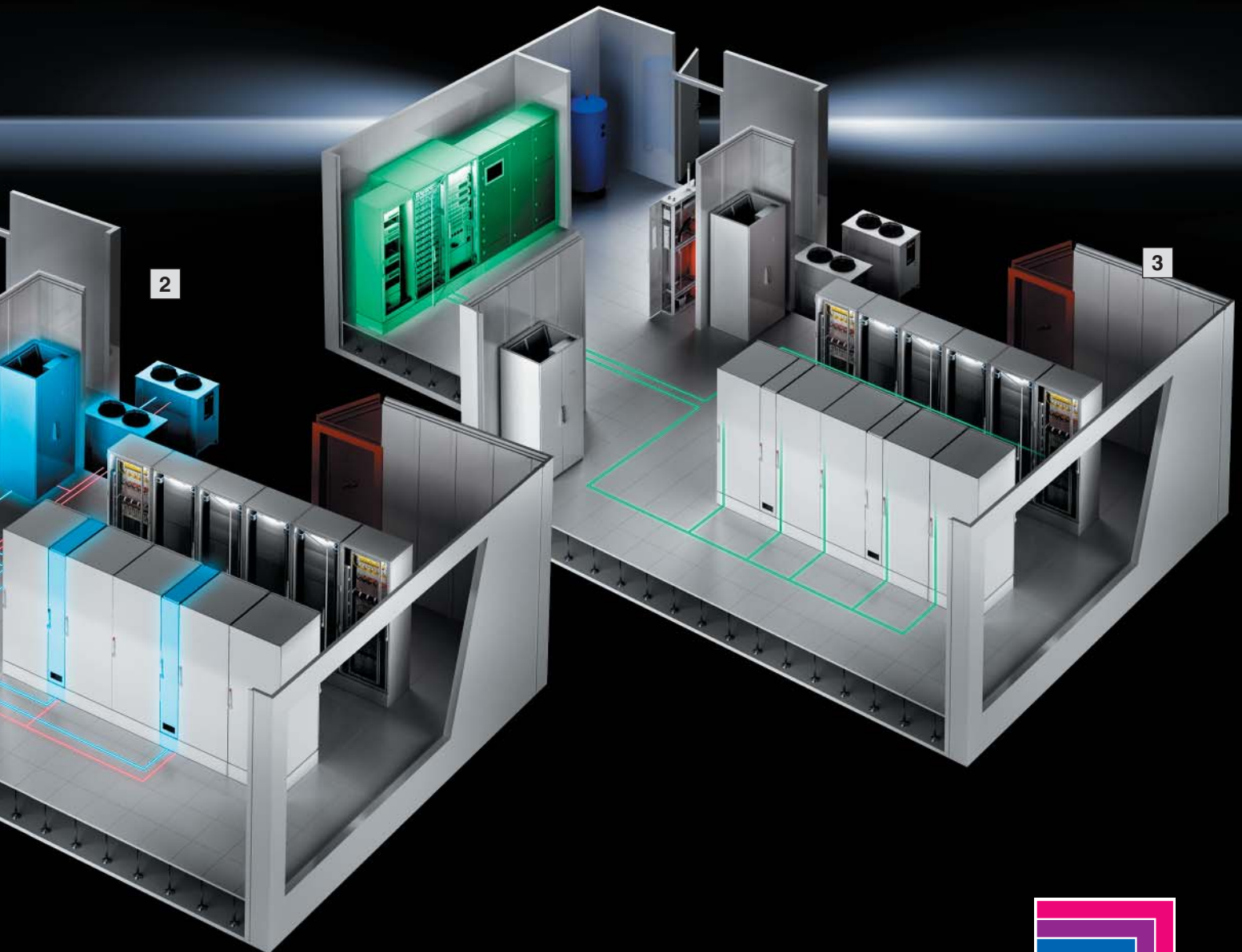

IT INFRASTRUCTURE

SOFTWARE & SERVICES



Rittal – The System.

Faster – better – worldwide.

- Enclosures
- Power Distribution
- Climate Control
- IT Infrastructure
- Software & Services

RITTAL GmbH & Co. KG
Postfach 1662 · D-35726 Herborn
Phone +49(0)2772 505-0 · Fax +49(0)2772 505-2319
E-Mail: info@rittal.de · www.rittal.com

ENCLOSURES

POWER DISTRIBUTION

CLIMATE CONTROL

IT INFRASTRUCTURE

SOFTWARE & SERVICES



FRIEDHELM LOH GROUP